



PARTS CATALOGUE

YZ450FW'07 (2S2A) OCEANIA,SOUTH AFRICA

YZ450FW/YZ450F
PARTS CATALOGUE
©2006 by Yamaha Motor Co., Ltd.
1st edition, August 2006
All rights reserved.
Any reprinting or unauthorized use
without the written permission of
Yamaha Motor Co., Ltd.
is expressly prohibited.
Printed in Japan.

A3

FOREWORD

This Parts Catalogue is related to the parts for the model(s) on the cover page. When you are ordering replacement parts, please refer to this Parts Catalogue and quote both part numbers and part names correctly.

1. Modifications or additions which have been made after the issue of the Parts Catalogue will be announced in the Parts News.

It is advisable that you make the necessary corrections to the Parts Catalogue according to the Parts News.

2. Abbreviations

The following abbreviations are used in this Parts Catalogue.

“UR” Use specified parts number.

“UN” Use as many as needed.

“AP” Alternate Parts

“LM” Locally Made (Parts need to be ordered locally)

“F#” Frame No. (Applicable machine No.)

“O/S” Over Size

3. The number of components for assembly

- Parts, which are to be supplied in an assembly, are listed with a dot (.) in front of the part name as shown below.
- The numeral appearing to the right of each component part indicates the quantity of parts for each assembly unit.

PART NO.	DESCRIPTION	Q'TY	REMARKS
2F5-83310-60	FRONT FLASHER LIGHT ASSY	2	
115-83311-60	.BULB (6V-18W)	1	

4. Applicable colours of graphics are represented in the “REMARKS” as shown below.

PART NO.	DESCRIPTION	Q'TY	REMARKS
2N4-24110-00-X5	FUEL TANK COMP.	2	MXR
3J1-24240-10	.GRAPHIC, FUEL TANK	1	FOR MXR

5. Note that the illustrations for reference in finding parts numbers are not to be used for assembling. When assembling, please use the applicable service manual.

6. The asterisk (*) before a reference number indicates modified items after the first edition.

FOREWORD

7. Applicable Serial No.

Engine Serial No.

Frame Serial No.

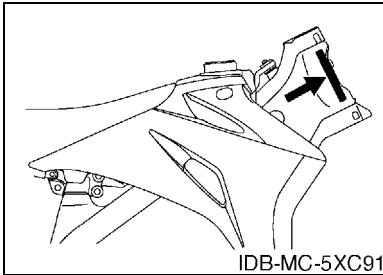
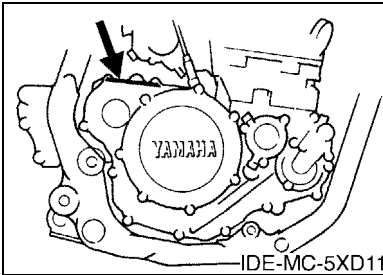

8. Applicable Colour Code (The (*) mark shows Model colour.)

Abbreviation	Colour Name	Colour Code
DPBSE(*)	DEEP PURPLISH BLUE SOLID E	0583
PWS1(*)	PURPLISH WHITE SOLID 1	0206

CONTENTS

ENGINE

CYLINDER	B2
CRANKSHAFT & PISTON	B4
VALVE	B5
CAMSHAFT & CHAIN	B7
WATER PUMP	B8
RADIATOR & HOSE	B9
OIL PUMP	B10
OIL CLEANER	B11
INTAKE	B12
CARBURETOR	B13
EXHAUST	C3
CRANKCASE	C4
CRANKCASE COVER 1	C6
STARTER	C8
CLUTCH	C9
TRANSMISSION	C10
SHIFT CAM & FORK	C12
SHIFT SHAFT	C13

CHASSIS

FRAME	C14
FENDER	D2
SIDE COVER	D4
REAR ARM	D5
REAR SUSPENSION	D7
STEERING	D9
FRONT FORK	D10
FUEL TANK	D13
SEAT	D15
FRONT WHEEL	E2
FRONT BRAKE CALIPER	E3
REAR WHEEL	E4
REAR BRAKE CALIPER	E6
STEERING HANDLE & CABLE	E7
FRONT MASTER CYLINDER	E8
STAND & FOOTREST	E9
REAR MASTER CYLINDER	E10
GENERATOR	E11
HANDLE SWITCH & LEVER	E12
ELECTRICAL 1	E13
ALTERNATE FOR CHASSIS	E14

ALTERNATE	E15
-----------------	-----

INDEX

NUMERICAL INDEX	M1
-----------------------	----

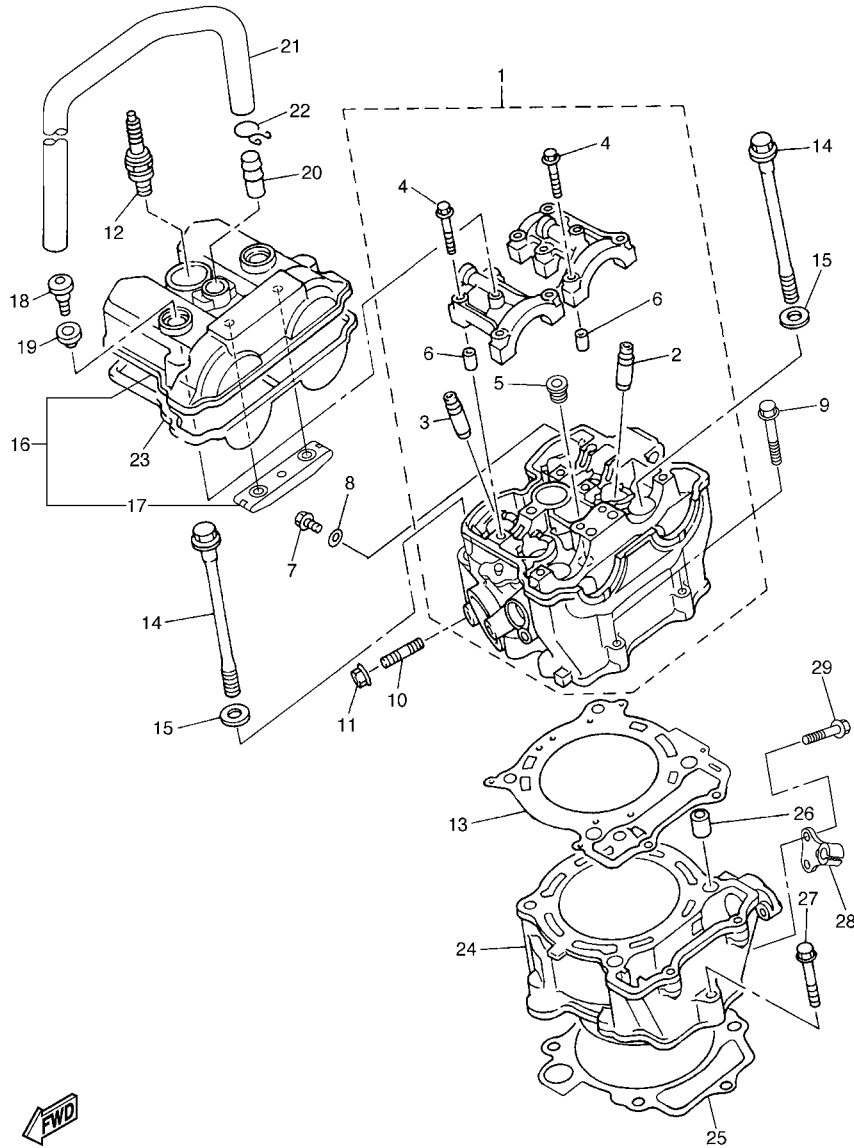
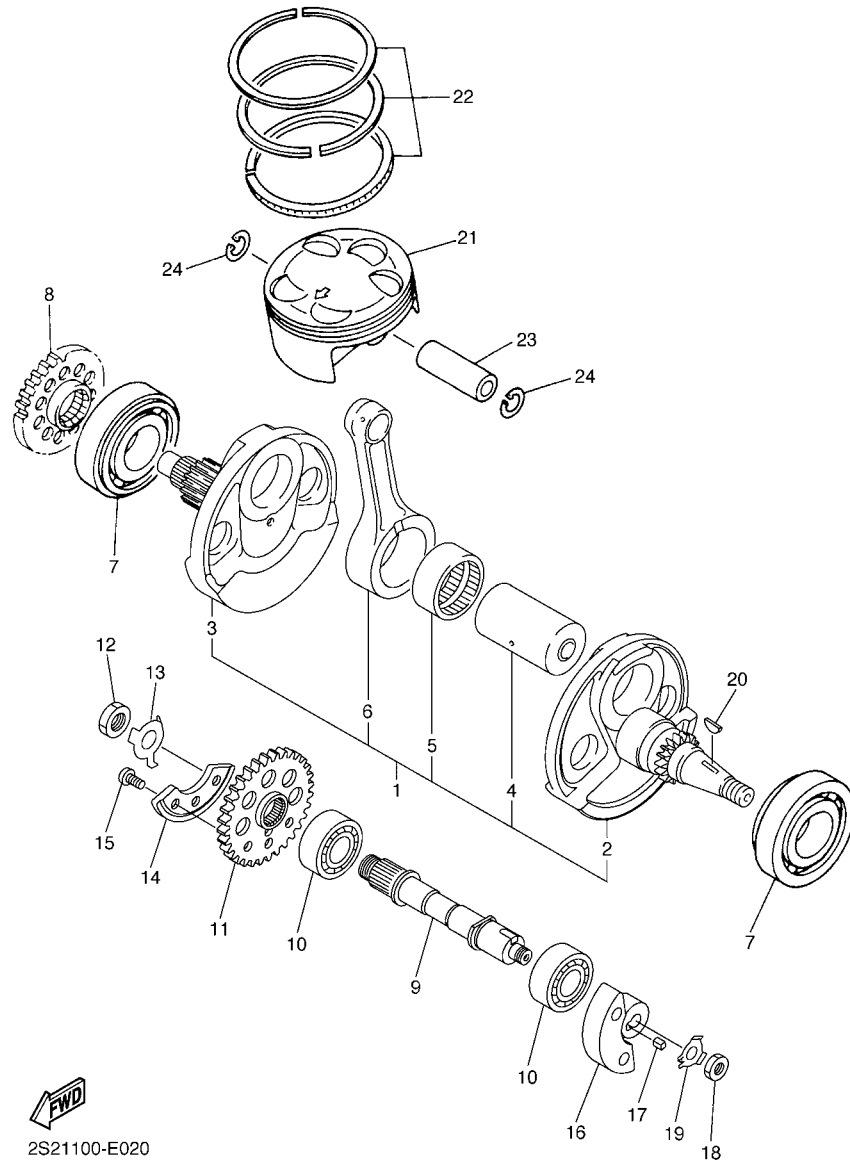

FIG. 1 CYLINDER

REF. NO.	PART NO.	DESCRIPTION	2S27	2S28	2S29	2S2A	REMARKS
1	2S2-11102-00	CYLINDER HEAD ASSY	1	1	1	1	
2	5TA-11133-10	.GUIDE, VALVE 1	3	3	3	3	
3	5TA-11134-10	.GUIDE, VALVE 2	2	2	2	2	
4	90105-06027	.BOLT, FLANGE	10	10	10	10	
5	90340-12007	.PLUG, STRAIGHT SCREW	1	1	1	1	
6	91808-16023	.PIN, DOWEL	4	4	4	4	
7	95022-06010	BOLT, FLANGE	1	1	1	1	
8	90430-06014	GASKET	1	1	1	1	
9	95022-06035	BOLT, FLANGE	2	2	2	2	
10	90116-08022	BOLT, STUD	1	1	1	1	
11	95702-08500	NUT, FLANGE	1	1	1	1	
12	94701-00411	PLUG, SPARK (NGK R CR8E)	1	1		1	STD
	94701-00410	PLUG, SPARK (NGK R CR9E)	1	1		1	AP
13	2S2-11181-00	GASKET, CYLINDER HEAD 1	1	1	1	1	
14	90105-10163	BOLT, FLANGE	4	4	4	4	
15	90201-10025	WASHER, PLATE	4	4	4	4	
16	2S2-11190-00	COVER, CYLINDER HEAD 1	1	1	1	1	
17	5BE-12241-00	.GUIDE, STOPPER 2	1	1	1	1	
18	90109-06203	BOLT	2	2	2	2	
19	5VY-1111G-00	RUBBER, MOUNT 1	2	2	2	2	
20	371-11167-01	PIPE, BREATHER 2	1	1	1	1	
21	2S2-11166-00	PIPE, BREATHER 1	1	1	1	1	
22	90467-140A4	CLIP	1	1	1	1	
23	2S2-11193-00	GASKET, HEAD COVER 1	1	1	1	1	
24	2S2-11311-10	CYLINDER 1	1	1	1	1	



2S27100-F010



2S21100-E020

FIG. 2 CRANKSHAFT & PISTON

REF. NO.	PART NO.	DESCRIPTION	2S27	2S28	2S29	2S2A	REMARKS
1	2S2-11400-00	CRANKSHAFT ASSY	1	1	1	1	
2	2S2-11412-00	.CRANK 1	1	1	1	1	
3	2S2-11422-00	.CRANK 2	1	1	1	1	
4	5TG-11681-00	.PIN, CRANK 1	1	1	1	1	
5	93310-63417	.BEARING	1	1	1	1	
6	2S2-11651-00	.ROD, CONNECTING	1	1	1	1	
7	93306-30633	BEARING	2	2	2	2	
8	2S2-11536-00	GEAR, DRIVE	1	1	1	1	
9	2S2-11455-00	SHAFT 1	1	1	1	1	
10	93304-20310	BEARING	2	2	2	2	
11	2S2-11531-00	GEAR, BALANCE WEIGHT	1	1	1	1	
12	90170-14171	NUT	1	1	1	1	
13	90215-14287	WASHER, LOCK	1	1	1	1	
14	2S2-11454-10	WEIGHT 1	1	1	1	1	
15	90149-06083	SCREW	3	3	3	3	
16	2S2-11464-10	WEIGHT 2	1	1	1	1	
17	90282-05034	KEY, STRAIGHT	1	1	1	1	
18	90170-10405	NUT	1	1	1	1	
19	90215-10009	WASHER, LOCK	1	1	1	1	
20	90280-03006	KEY, WOODRUFF	1	1	1	1	
21	2S2-11631-10	PISTON (STD)	1	1	1	1	
22	5JG-11603-00	PISTON RING SET (STD)	1	1	1	1	
23	5TA-11633-00	PIN, PISTON	1	1	1	1	
24	93420-18082	CIRCLIP	2	2	2	2	

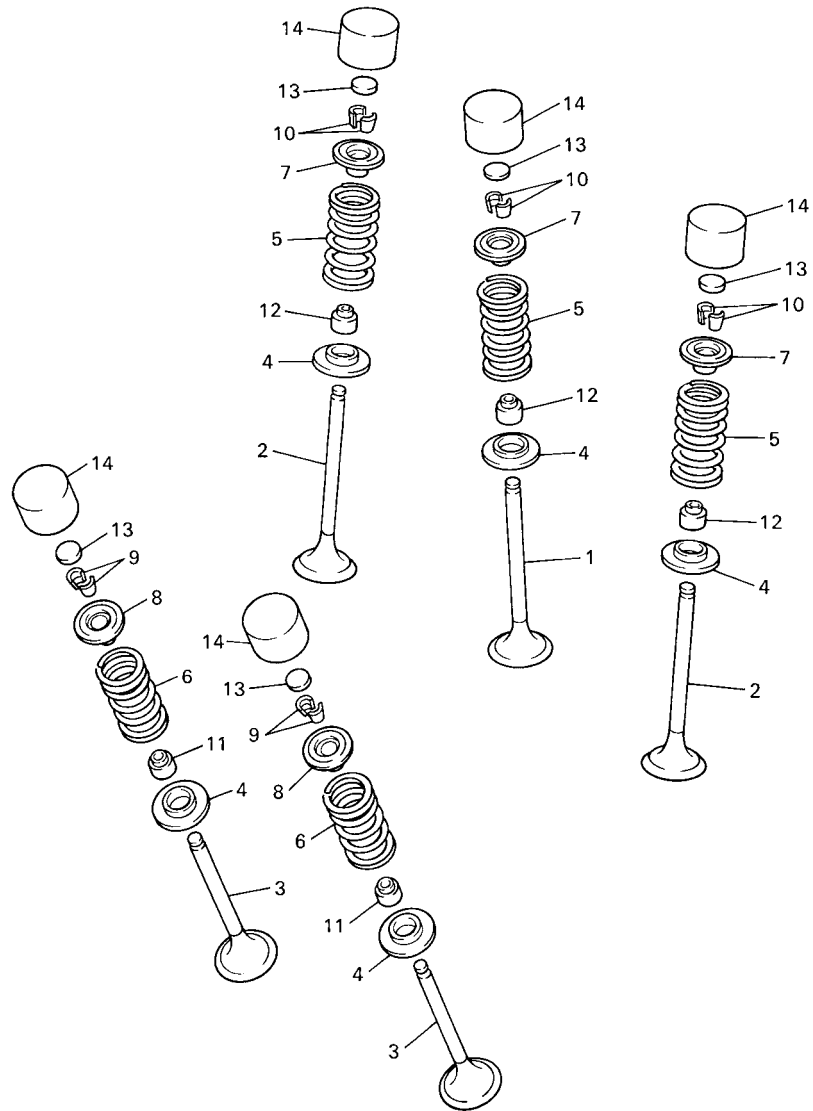

5BE100-8030

FIG. 3 VALVE

REF. NO.	PART NO.	DESCRIPTION	2S27	2S28	2S29	2S2A	REMARKS
1	5TA-12111-00	VALVE, INTAKE	1	1	1	1	
2	5TA-12112-00	VALVE, INTAKE 2	2	2	2	2	
3	5TA-12121-00	VALVE, EXHAUST	2	2	2	2	
4	3GM-12126-00	SEAT, VALVE SPRING 2	5	5	5	5	
5	5TA-12113-00	SPRING, VALVE INNER	3	3	3	3	
6	5TA-12114-00	SPRING, VALVE OUTER	2	2	2	2	
7	5BE-12117-00	RETAINER, VALVE SPRING	3	3	3	3	
8	4GY-12117-00	RETAINER, VALVE SPRING	2	2	2	2	
9	1AA-12118-00	COTTER, VALVE	4	4	4	4	
10	1WG-12118-00	COTTER, VALVE	6	6	6	6	
11	33M-12119-00	SEAL, VALVE STEM	2	2	2	2	
12	4SV-12119-00	SEAL, VALVE STEM	3	3	3	3	
13	3LD-12168-00	PAD, ADJUSTING (1.20)	5	5	5	5	UR
	3LD-12168-20	PAD, ADJUSTING (1.25)	5	5	5	5	UR
	3LD-12168-40	PAD, ADJUSTING (1.30)	5	5	5	5	UR
	3LD-12168-60	PAD, ADJUSTING (1.35)	5	5	5	5	UR
	3LD-12168-80	PAD, ADJUSTING (1.40)	5	5	5	5	UR
	3LD-12168-A0	PAD, ADJUSTING (1.45)	5	5	5	5	UR
	3LD-12168-F0	PAD, ADJUSTING (1.50)	5	5	5	5	UR
	3LD-12168-H1	PAD, ADJUSTING (1.55)	5	5	5	5	UR
	3LD-12168-K1	PAD, ADJUSTING (1.60)	5	5	5	5	UR
	3LD-12168-M1	PAD, ADJUSTING (1.65)	5	5	5	5	UR
	3LD-12168-R1	PAD, ADJUSTING (1.70)	5	5	5	5	UR
	3LD-12168-U1	PAD, ADJUSTING (1.75)	5	5	5	5	UR
	3LD-12168-W1	PAD, ADJUSTING (1.80)	5	5	5	5	UR
	3LD-12168-Y1	PAD, ADJUSTING (1.85)	5	5	5	5	UR
	3LD-12169-11	PAD, ADJUSTING (1.90)	5	5	5	5	UR

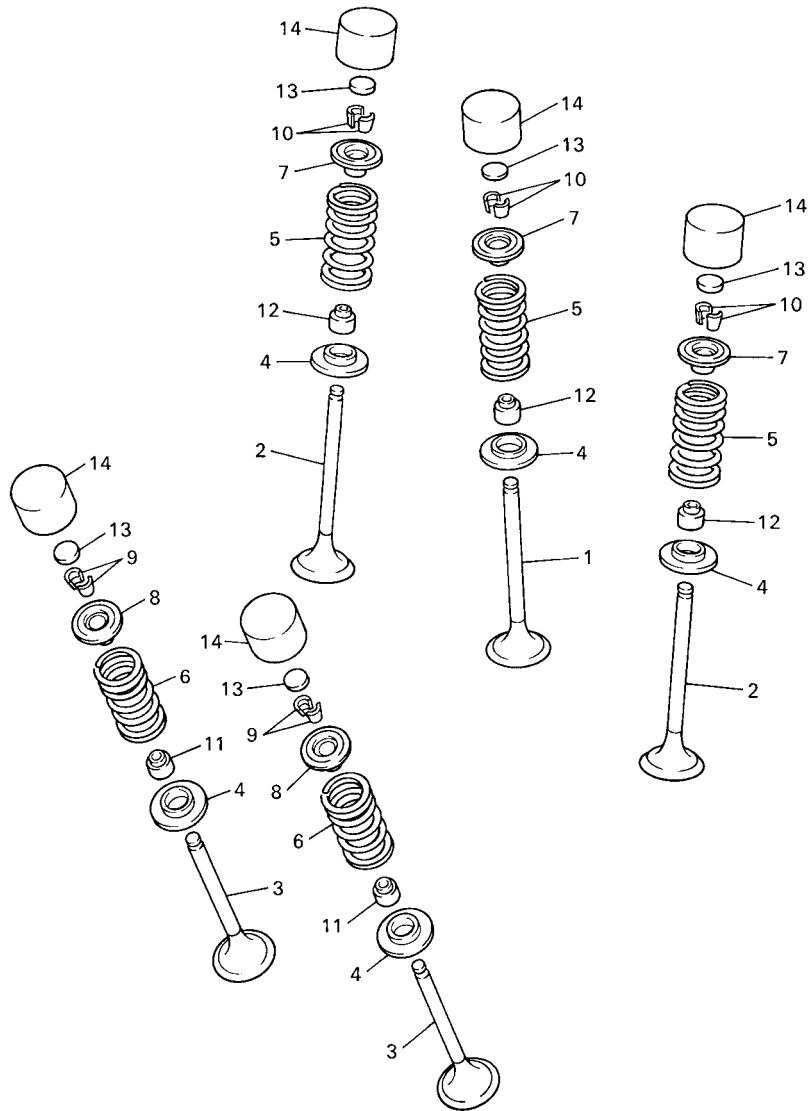

5BE100-8030

FIG. 3 VALVE

REF. NO.	PART NO.	DESCRIPTION	2S27	2S28	2S29	2S2A	REMARKS
13	3LD-12169-31	PAD, ADJUSTING (1.95)	5	5	5	5	UR
	3LD-12169-50	PAD, ADJUSTING (2.00)	5	5	5	5	UR
	3LD-12169-70	PAD, ADJUSTING (2.05)	5	5	5	5	UR
	3LD-12169-90	PAD, ADJUSTING (2.10)	5	5	5	5	UR
	3LD-12169-E0	PAD, ADJUSTING (2.15)	5	5	5	5	UR
	3LD-12169-G0	PAD, ADJUSTING (2.20)	5	5	5	5	UR
	3LD-12169-J0	PAD, ADJUSTING (2.25)	5	5	5	5	UR
	3LD-12169-L0	PAD, ADJUSTING (2.30)	5	5	5	5	UR
	3LD-12169-N0	PAD, ADJUSTING (2.35)	5	5	5	5	UR
	3LD-12169-T0	PAD, ADJUSTING (2.40)	5	5	5	5	UR
14	3FV-12153-10	LIFTER, VALVE	5	5	5	5	YELLOW

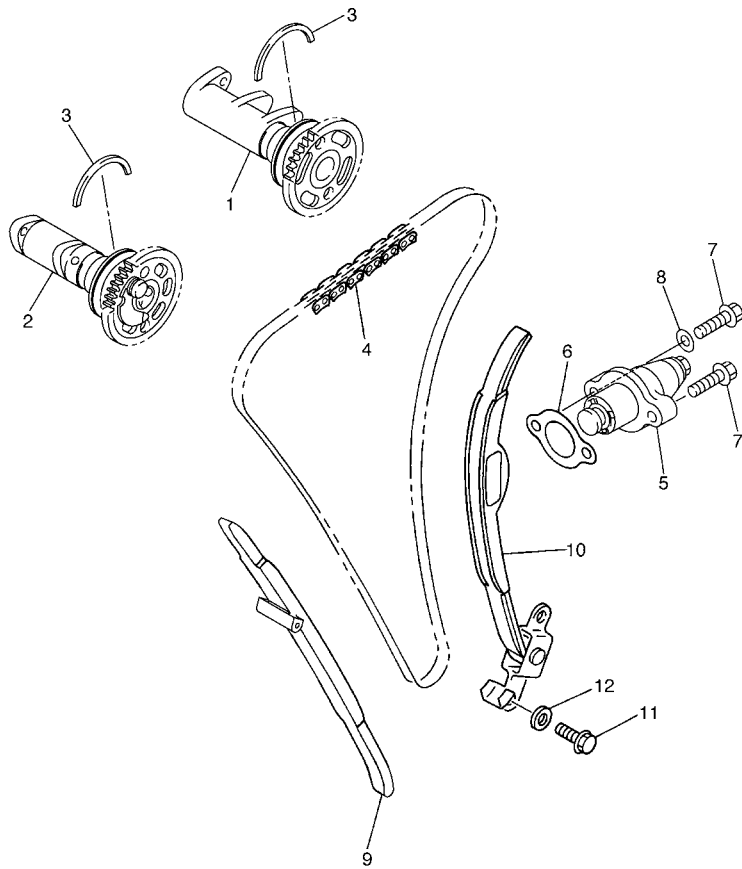

FIG. 4 CAMSHAFT & CHAIN

REF. NO.	PART NO.	DESCRIPTION	2S27	2S28	2S29	2S2A	REMARKS
1	5TA-12170-20	CAMSHAFT ASSY 1	1	1	1	1	
2	5TA-12180-20	CAMSHAFT ASSY 2	1	1	1	1	
3	93440-41178	CIRCLIP	2	2	2	2	
4	94591-57118	CHAIN (98XRH2010-118M)	1	1	1	1	
5	5TA-12210-10	TENSIONER ASSY, CAM CHAIN	1	1	1	1	
6	4FM-12213-00	GASKET, TENSIONER CASE	1	1	1	1	
7	95022-06025	BOLT, FLANGE	2	2	2	2	
8	90430-06014	GASKET	1	1	1	1	
9	2S2-12251-00	DAMPER, CHAIN 1	1	1	1	1	
10	5TA-12252-00	DAMPER, CHAIN 2	1	1	1	1	
11	97022-06016	BOLT	2	2	2	2	
12	92902-06600	WASHER, PLATE	2	2	2	2	



2S27100-F040

FIG. 5 WATER PUMP

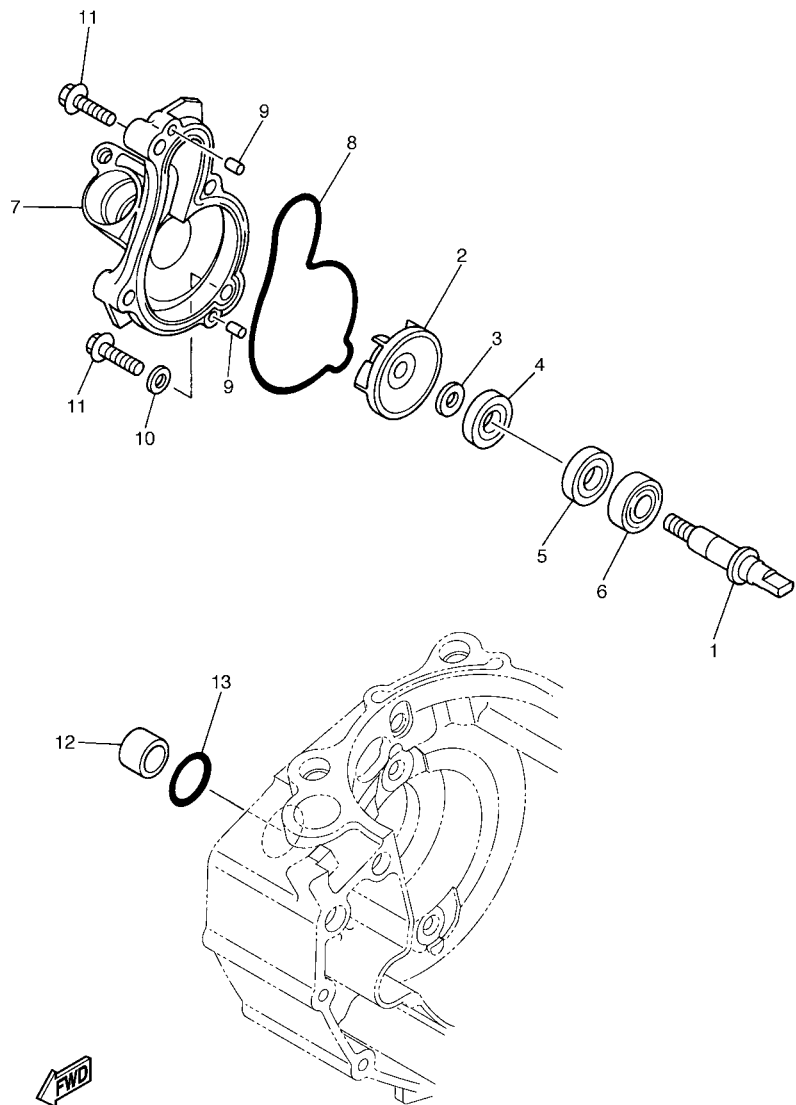

2S21100-E050

REF. NO.	PART NO.	DESCRIPTION	2S27	2S28	2S29	2S2A	REMARKS
1	5GR-12458-00	SHAFT, IMPELLER	1	1	1	1	
2	5DJ-12451-00	IMPELLER, WATER PUMP	1	1	1	1	
3	90201-08512	WASHER, PLATE	1	1	1	1	
4	93109-11073	OIL SEAL	1	1	1	1	
5	93102-12106	OIL SEAL (SD 12-22-5 HS)	1	1	1	1	
6	93306-00105	BEARING	1	1	1	1	
7	5BE-12422-20	COVER, HOUSING	1	1	1	1	
8	5BE-12439-00	O-RING	1	1	1	1	
9	93604-10011	PIN, DOWEL	2	2	2	2	
10	90430-06014	GASKET	1	1	1	1	
11	95022-06030	BOLT, FLANGE	4	4	4	4	
12	5BE-12564-00	PIPE, WATER	1	1	1	1	
13	93210-19758	O-RING	1	1	1	1	

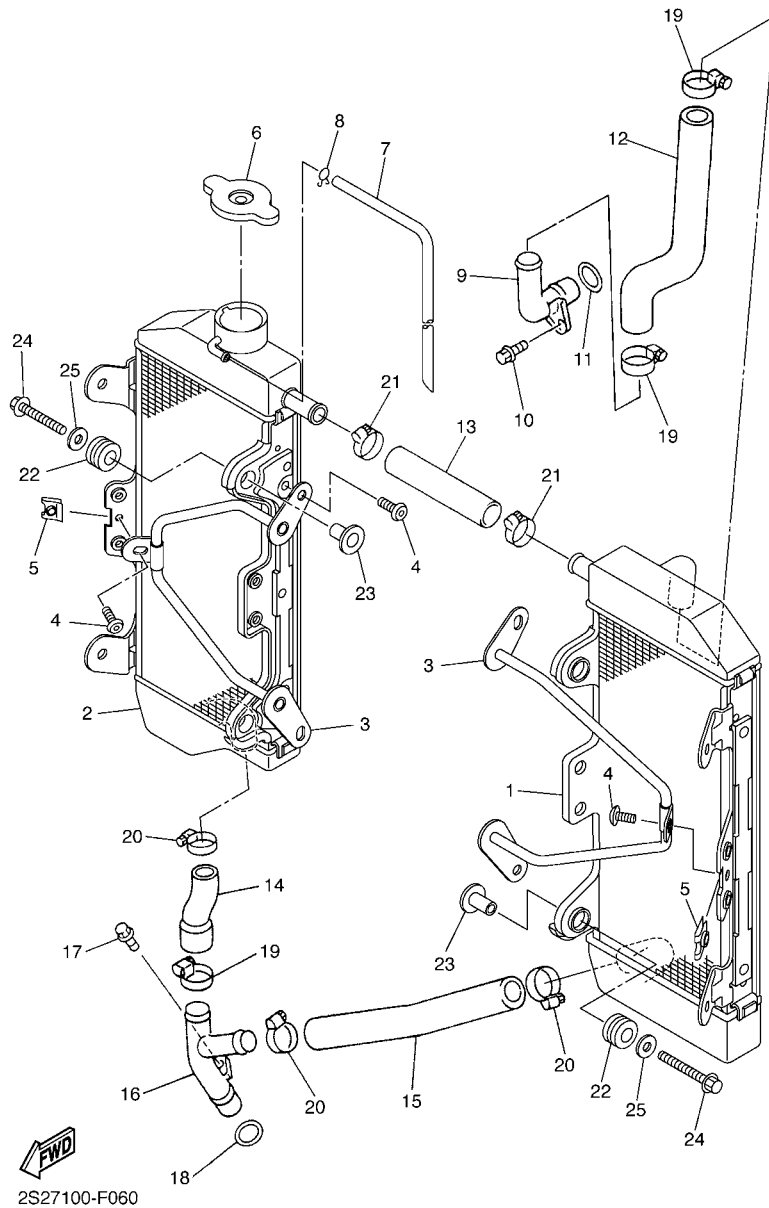
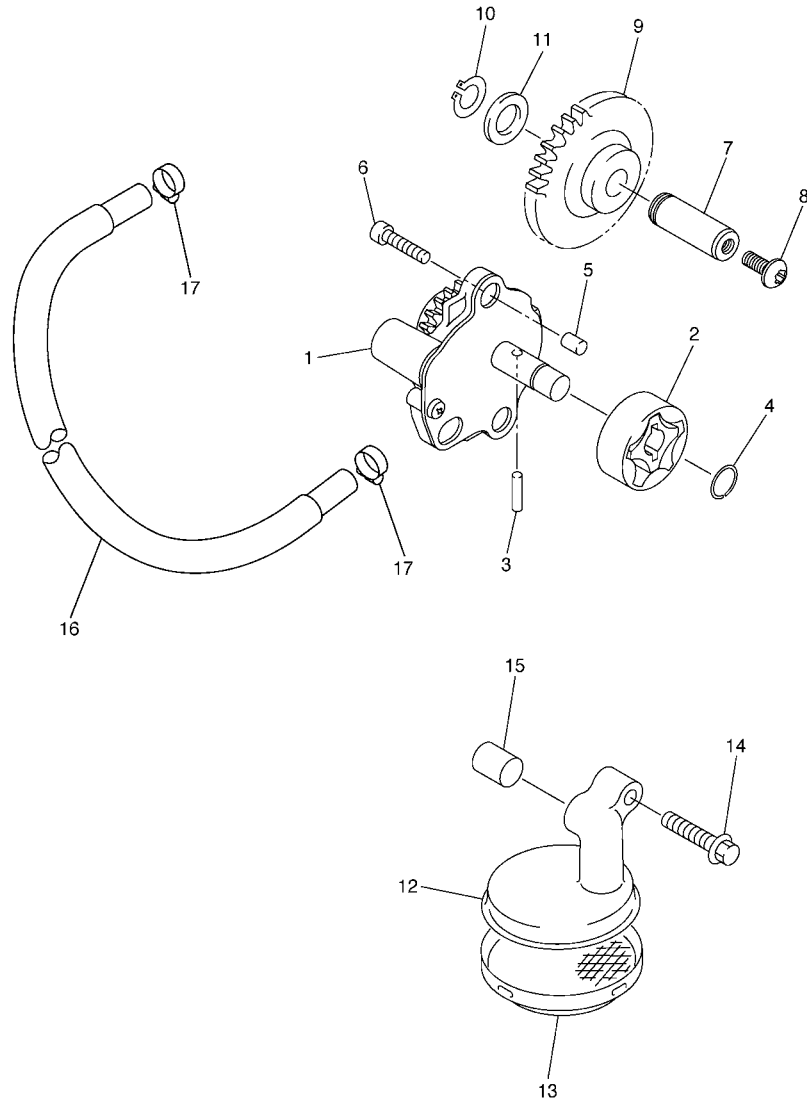

FIG. 6 RADIATOR & HOSE

REF. NO.	PART NO.	DESCRIPTION	2S27	2S28	2S29	2S2A	REMARKS
1	2S2-1240A-70	RADIATOR ASSY	1	1	1	1	
2	2S2-12461-70	RADIATOR ASSY	1	1	1	1	
3	2S2-12464-70	.STAY, RADIATOR	2	2	2	2	
4	92012-06010	.BOLT, BUTTON HEAD	6	6	6	6	
5	90183-060A6	.NUT, SPRING	2	2	2	2	
6	22W-12462-00	CAP, RADIATOR	1	1	1	1	
7	91A20-05065	TUBE, FLEXIBLE VINYL	1	1	1	1	
8	90467-090A2	CLIP	1	1	1	1	
9	2S2-12481-00	PIPE 1	1	1	1	1	
10	91312-06012	BOLT	1	1	1	1	
11	93210-16500	O-RING	1	1	1	1	
12	2S2-12576-00	HOSE 1	1	1	1	1	
13	1C3-12482-00	PIPE 2	1	1	1	1	
14	2S2-12578-00	HOSE 3	1	1	1	1	
15	2S2-12579-00	HOSE 4	1	1	1	1	
16	2S2-12482-00	PIPE 2	1	1	1	1	
17	95022-06012	BOLT, FLANGE	1	1	1	1	
18	93210-16500	O-RING	1	1	1	1	
19	90450-28001	HOSE CLAMP ASSY	3	3	3	3	
20	90450-25001	HOSE CLAMP ASSY	3	3	3	3	
21	90450-22001	HOSE CLAMP ASSY	2	2	2	2	
22	90480-15528	GROMMET	4	4	4	4	
23	90387-06065	COLLAR	4	4	4	4	
24	90105-06111	BOLT, FLANGE	4	4	4	4	
25	90201-06571	WASHER, PLATE	4	4	4	4	

FIG. 7 OIL PUMP



REF. NO.	PART NO.	DESCRIPTION	2S27	2S28	2S29	2S2A	REMARKS
1	2S2-13300-10	OIL PUMP ASSY	1	1	1	1	
2	5TA-13320-00	ROTOR ASSY 2	1	1	1	1	
3	93603-16219	PIN, DOWEL	1	1	1	1	
4	93440-10153	CIRCLIP	1	1	1	1	
5	99530-08012	PIN, DOWEL	2	2	2	2	
6	91312-06030	BOLT	2	2	2	2	
7	2S2-13342-00	SHAFT, IDLE GEAR	1	1	1	1	
8	90149-06068	SCREW	1	1	1	1	
9	2S2-13341-00	GEAR, OIL PUMP IDLE	1	1	1	1	
10	99009-12400	CIRCLIP	1	1	1	1	
11	90201-12166	WASHER, PLATE	1	1	1	1	
12	2S2-13412-00	HOUSING, STRAINER	1	1	1	1	
13	5BE-13411-00	STRAINER, OIL	1	1	1	1	
14	95022-06030	BOLT, FLANGE	1	1	1	1	
15	99530-10114	PIN, DOWEL	1	1	1	1	
16	90445-14009	HOSE	1	1	1	1	
17	90450-17001	HOSE CLAMP ASSY	2	2	2	2	



2S21100-E070

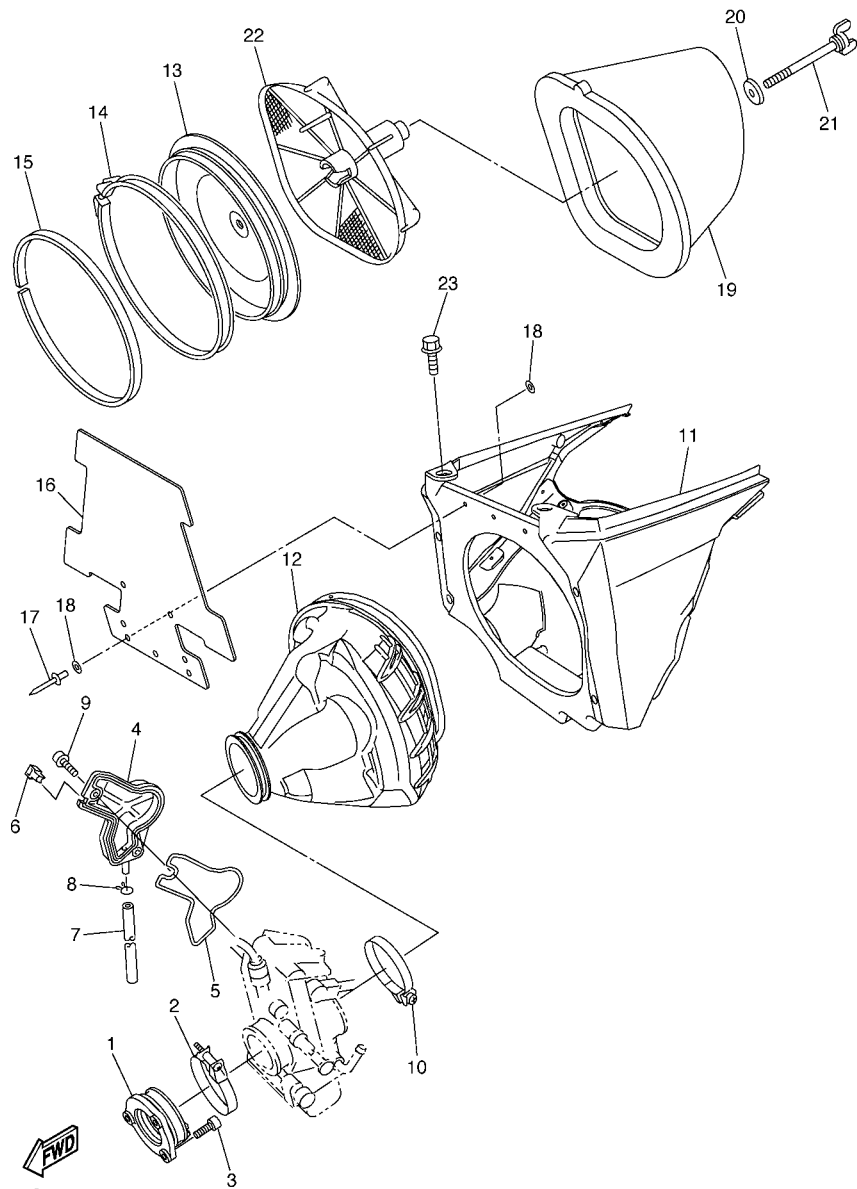
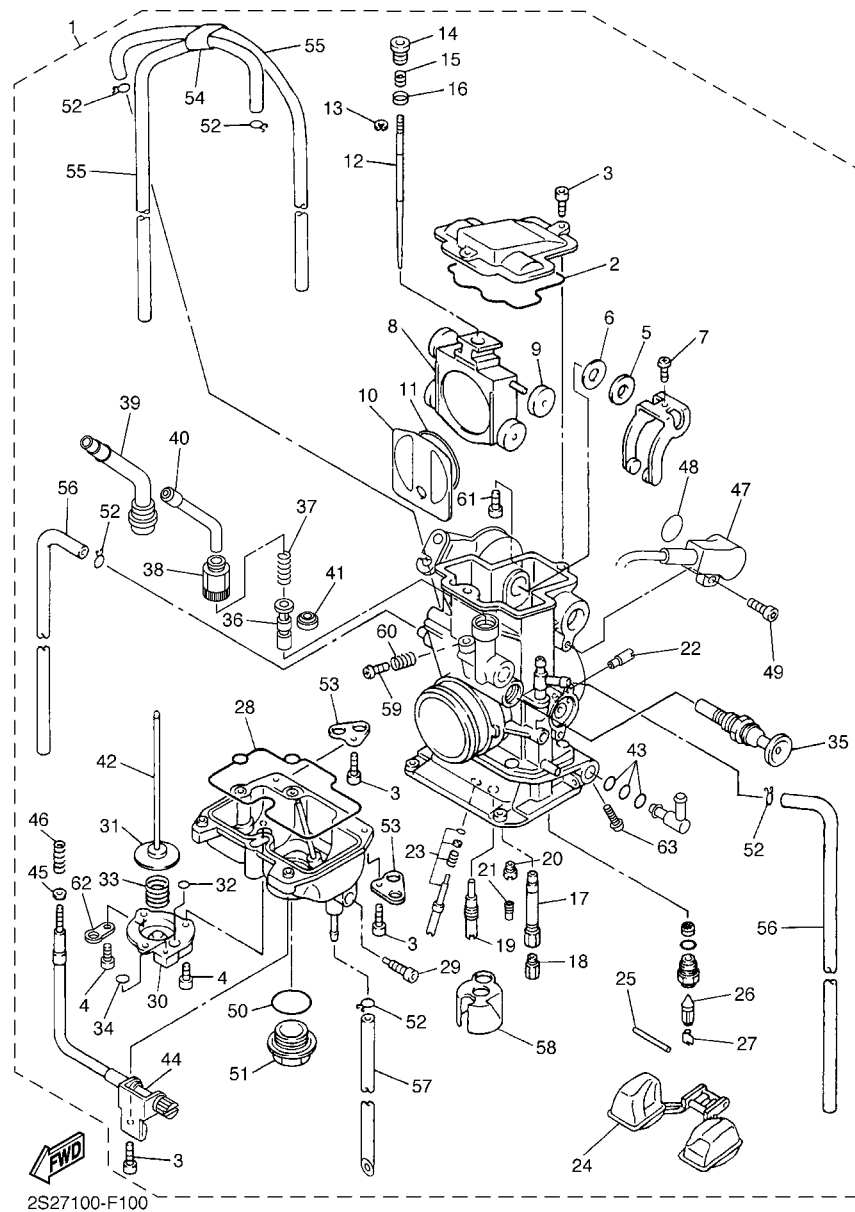

FIG. 9 INTAKE

REF. NO.	PART NO.	DESCRIPTION	2S27	2S28	2S29	2S2A	REMARKS
1	2S2-13597-00	JOINT, CARBURETOR 3	1	1	1	1	
2	90450-57010	HOSE CLAMP ASSY	1	1	1	1	
3	91312-06020	BOLT	3	3	3	3	
4	5TA-14293-00	COVER 1	1	1	1	1	
5	5TA-14227-00	GASKET	1	1	1	1	
6	5TA-14239-00	SEAL	1	1	1	1	
7	5TA-14987-00	HOSE	1	1	1	1	
8	3TJ-14137-40	CLIP	1	1	1	1	
9	90110-05038	BOLT, HEXAGON SOCKET HEAD	2	2	2	2	
10	90450-61002	HOSE CLAMP ASSY	1	1	1	1	
11	2S2-14401-70	AIR CLEANER CASE ASSY	1	1	1	1	
12	2S2-14453-10	JOINT, AIR CLEANER 1	1	1	1	1	
13	5NY-14459-00	HOLDER, GUIDE	1	1	1	1	
14	5NY-14455-20	BAND	1	1	1	1	
15	5NY-14442-00	SPACER	1	1	1	1	
16	5XC-14417-90	COVER 1	1	1	1	1	
17	90267-32070	RIVET, BLIND	3	3	3	3	
18	90201-03313	WASHER, PLATE	6	6	6	6	
19	4XM-14451-00	ELEMENT, AIR CLEANER	1	1	1	1	
20	90209-06014	WASHER	1	1	1	1	
21	90122-06005	BOLT, WING	1	1	1	1	
22	5BE-14458-00	GUIDE	1	1	1	1	
23	90109-067F4	BOLT	2	2	2	2	



2S27100-F100

FIG. 10 CARBURETOR

REF. NO.	PART NO.	DESCRIPTION	2S27	2S28	2S29	2S2A	REMARKS
1	2S2-14101-70	CARBURETOR ASSY 1	1	1	1	1	
2	5JG-14959-00	.GASKET	1	1	1	1	
3	91316-04012	.BOLT	6	6	6	6	
4	688-14592-00	.SCREW	3	3	3	3	
5	90202-08045	.WASHER, PLATE	1	1	1	1	
6	5JG-14951-00	.WASHER	1	1	1	1	
7	5JG-14522-00	.SCREW, ADJUST	1	1	1	1	
8	2S2-14388-00	.VALVE, VACUUM CONTROL	1	1	1	1	
9	3TJ-14267-40	.ROLLER	1	1	1	1	
10	5JG-14546-01	.VALVE, NEEDLE	1	1	1	1	
11	4FN-14997-00	.SEAL	1	1	1	1	
12	5TA-14916-LR	.NEEDLE (#NFLR)	1	1	1	1	STD
	5TA-14916-LN	.NEEDLE (#NFLN)	1	1	1	1	AP
	5TA-14916-LP	.NEEDLE (#NFLP)	1	1	1	1	AP
	5TA-14916-L1	.NEEDLE (#NFLQ)	1	1	1	1	AP
	5TA-14916-LS	.NEEDLE (#NFLS)	1	1	1	1	AP
	5TA-14916-LT	.NEEDLE (#NFLT)	1	1	1	1	AP
	5TA-14916-LU	.NEEDLE (#NFLU)	1	1	1	1	AP
	5TA-14916-PN	.NEEDLE (#NFPP)	1	1	1	1	AP
	5TA-14916-PP	.NEEDLE (#NFPP)	1	1	1	1	AP
	5TA-14916-P1	.NEEDLE (#NFPPQ)	1	1	1	1	AP
	5TA-14916-PR	.NEEDLE (#NFPR)	1	1	1	1	AP
	5TA-14916-PS	.NEEDLE (#NFPS)	1	1	1	1	AP
	5TA-14916-PT	.NEEDLE (#NFPT)	1	1	1	1	AP
	5TA-14916-PU	.NEEDLE (#NFPU)	1	1	1	1	AP
13	3TJ-14159-40	.CLIP	1	1	1	1	
14	5JG-14521-00	.SCREW, ADJUST	1	1	1	1	

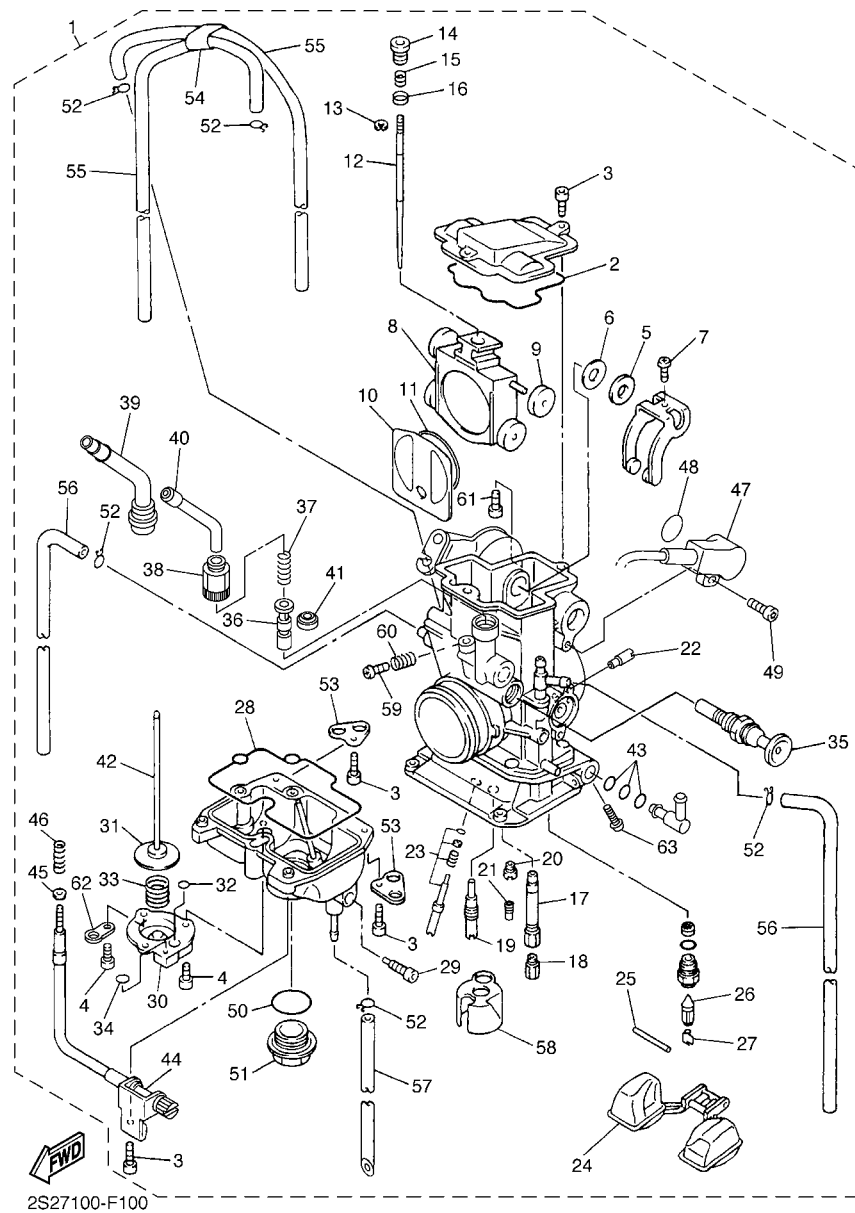

2S27100-F100

FIG. 10 CARBURETOR

REF. NO.	PART NO.	DESCRIPTION	2S27	2S28	2S29	2S2A	REMARKS
15	5JG-14275-00	.SPRING	1	1	1	1	
16	5JG-14264-00	.COLLAR	1	1	1	1	
17	5XD-14947-00	.NOZZLE, MAIN	1	1	1	1	
18	4MX-14943-39	.JET, MAIN (#160)	1	1	1	1	STD
	4MX-14943-87	.JET, MAIN (#148)	1	1	1	1	AP
	4MX-14943-37	.JET, MAIN (#150)	1	1	1	1	AP
	4MX-14943-88	.JET, MAIN (#152)	1	1	1	1	AP
	4MX-14943-38	.JET, MAIN (#155)	1	1	1	1	AP
	4MX-14943-89	.JET, MAIN (#158)	1	1	1	1	AP
	4MX-14943-90	.JET, MAIN (#162)	1	1	1	1	AP
	4MX-14943-40	.JET, MAIN (#165)	1	1	1	1	AP
	4MX-14943-91	.JET, MAIN (#168)	1	1	1	1	AP
	4MX-14943-41	.JET, MAIN (#170)	1	1	1	1	AP
	4MX-14943-92	.JET, MAIN (#172)	1	1	1	1	AP
19	4MX-14948-05	.JET, SLOW (#45)	1	1	1	1	STD
	4MX-14948-02	.JET, SLOW (#38)	1	1	1	1	AP
	4MX-14948-03	.JET, SLOW (#40)	1	1	1	1	AP
	4MX-14948-04	.JET, SLOW (#42)	1	1	1	1	AP
	4MX-14948-06	.JET, SLOW (#48)	1	1	1	1	AP
	4MX-14948-07	.JET, SLOW (#50)	1	1	1	1	AP
	4MX-14948-08	.JET, SLOW (#52)	1	1	1	1	AP
20	3TJ-1494F-16	.JET (#72)	1	1	1	1	STD
	3TJ-1494F-14	.JET (#68)	1	1	1	1	AP
	3TJ-1494F-15	.JET (#70)	1	1	1	1	AP
	3TJ-1494F-17	.JET (#75)	1	1	1	1	AP
	3TJ-1494F-18	.JET (#78)	1	1	1	1	AP
21	4JT-1494F-09	.JET (#55)	1	1	1	1	STD

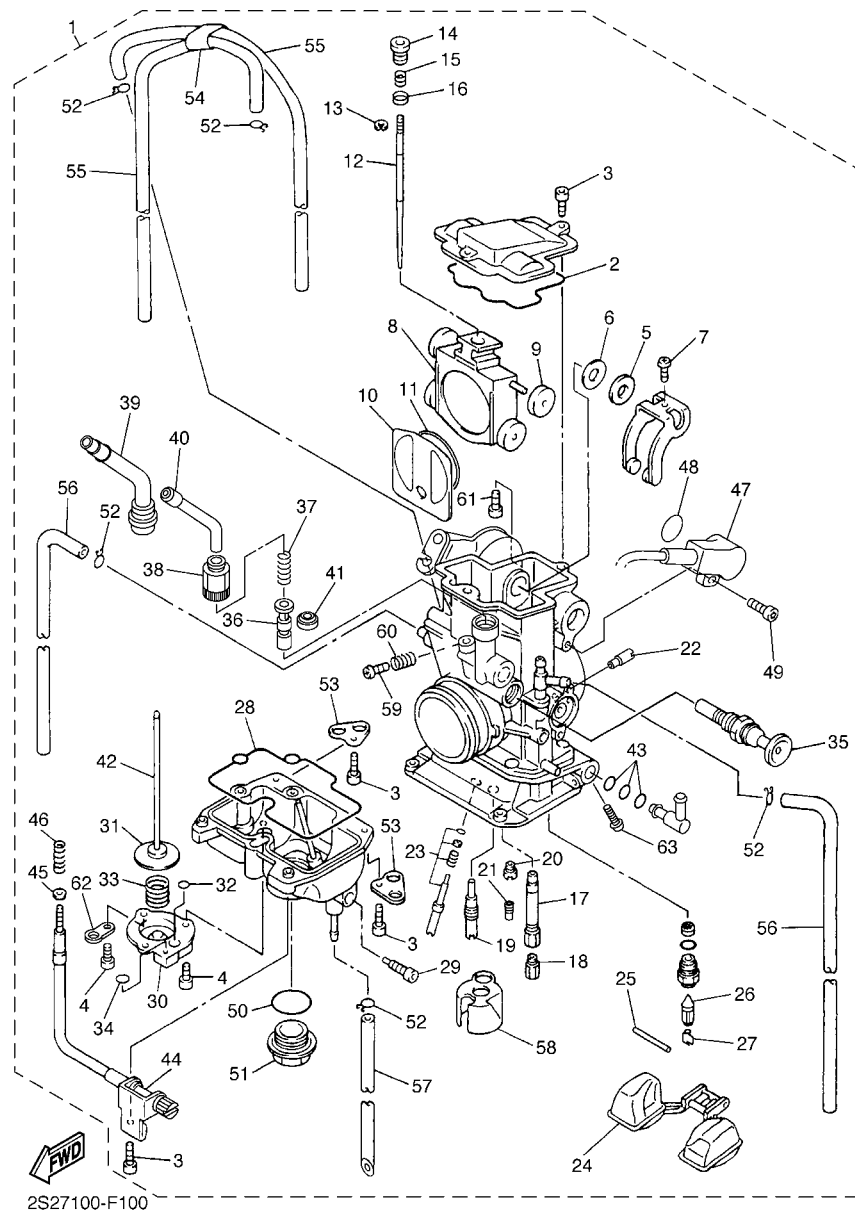

2S27100-F100

FIG. 10 CARBURETOR

REF. NO.	PART NO.	DESCRIPTION	2S27	2S28	2S29	2S2A	REMARKS
21	4JT-1494F-05	.JET (#45)	1	1	1	1	AP
	4JT-1494F-07	.JET (#50)	1	1	1	1	AP
	4JT-1494F-11	.JET (#60)	1	1	1	1	AP
	4JT-1494F-13	.JET (#65)	1	1	1	1	AP
22	5TA-14943-27	.JET, MAIN (#100)	1	1	1	1	
23	5NL-14105-00	.PILOT SCREW SET	1	1	1	1	
24	4SR-14985-00	.FLOAT	1	1	1	1	
25	676-14548-00	.PIN, FLOAT ARM	1	1	1	1	
26	4MX-14392-00	.VALVE, NEEDLE	1	1	1	1	
27	633-14159-00	.CLIP	1	1	1	1	
28	5JG-14984-00	.GASKET, FLOAT CHAMBER	1	1	1	1	
29	3TJ-14191-40	.PLUG, DRAIN	1	1	1	1	
30	3TJ-14293-40	.COVER 1	1	1	1	1	
31	5JG-14940-17	.DIAPHRAGM ASSY	1	1	1	1	STD
	5JG-14940-16	.DIAPHRAGM ASSY	1	1	1	1	AP
	5JG-14940-18	.DIAPHRAGM ASSY	1	1	1	1	AP
32	3TJ-14536-40	.GASKET	1	1	1	1	
33	3TJ-14933-40	.SPRING, DIAPHRAGM	1	1	1	1	
34	6H4-14561-00	.O-RING	1	1	1	1	
35	5XC-14171-00	.PLUNGER, STARTER	1	1	1	1	
36	5TA-14371-00	.PLUNGER, STARTER	1	1	1	1	
37	5TA-14335-00	.SPRING, PLUNGER	1	1	1	1	
38	5TA-14991-00	.SCREW	1	1	1	1	
39	2S2-14374-00	.CAP, PLUNGER	1	1	1	1	
40	5TA-14155-00	.GUIDE, CABLE	1	1	1	1	
41	5TA-14997-00	.SEAL	1	1	1	1	
42	5JG-14379-00	.ROD, STARTER	1	1	1	1	

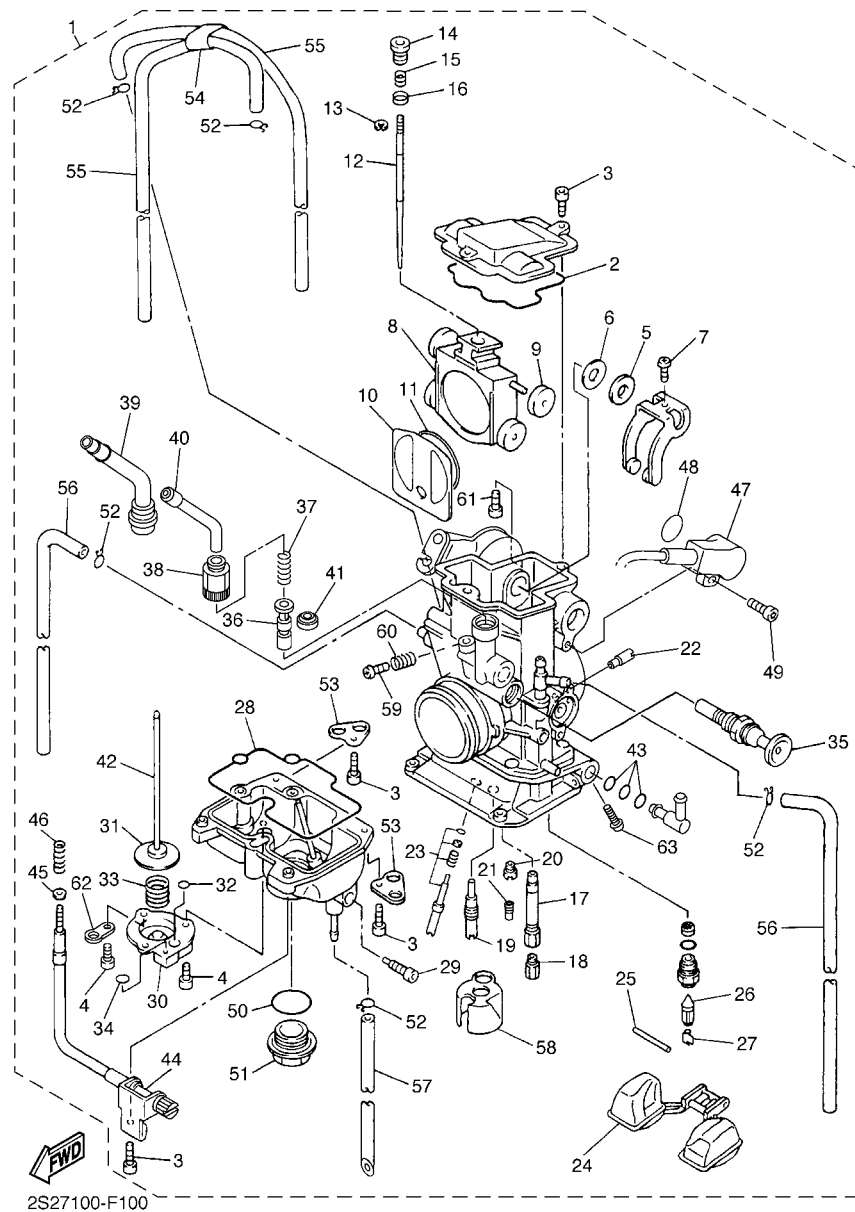

2S27100-F100

FIG. 10 CARBURETOR

REF. NO.	PART NO.	DESCRIPTION	2S27	2S28	2S29	2S2A	REMARKS
43	3TJ-14564-40	.O-RING	3	3	3	3	
44	5XC-14922-00	.SCREW, THROTTLE	1	1	1	1	
45	90201-08410	.WASHER, PLATE	1	1	1	1	
46	5TA-14934-00	.SPRING, THROTTLE STOP	1	1	1	1	
47	5XC-85885-00	.THROTTLE SENSOR ASSY	1	1	1	1	
48	5NX-14562-00	.O-RING	1	1	1	1	
49	5NX-14216-00	.SCREW	1	1	1	1	
50	4MX-14561-00	.O-RING	1	1	1	1	
51	4MX-14115-00	.PLUG, SCREW	1	1	1	1	
52	3TJ-14137-40	.CLIP	5	5	5	5	
53	5BE-14146-00	.PLATE	2	2	2	2	
54	5TA-14261-00	.HOLDER	1	1	1	1	
55	5UL-14196-00	.PIPE	2	2	2	2	
56	5TA-14197-00	.PIPE	2	2	2	2	
57	5TJ-14987-00	.HOSE	1	1	1	1	
58	5JG-14346-00	.PLATE	1	1	1	1	
59	5JG-14565-00	.SCREW	1	1	1	1	
60	5JG-14531-00	.SPRING, ADJUST SCREW	1	1	1	1	
61	5JG-14591-00	.SCREW	1	1	1	1	
62	5PA-14146-00	.PLATE	1	1	1	1	
63	5XD-14325-00	.SCREW, PAN HEAD	1	1	1	1	

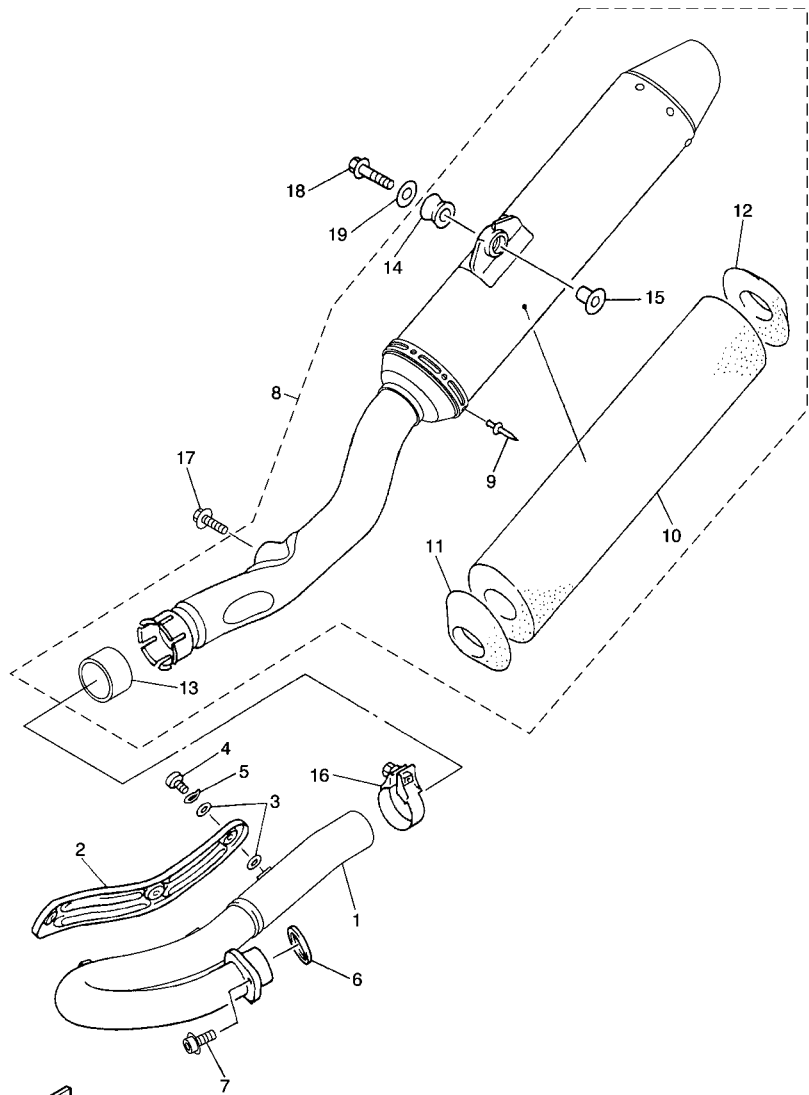

2S27100-F110

FIG. 11 EXHAUST

REF. NO.	PART NO.	DESCRIPTION	2S27	2S28	2S29	2S2A	REMARKS
1	2S2-14611-20	PIPE, EXHAUST 1	1	1	1	1	
2	5TA-14628-00	PROTECTOR, EXHAUST PIPE	1	1	1	1	
3	4BD-14766-00	WASHER, PROTECTOR	6	6	6	6	
4	98980-06008	SCREW, BIND	3	3	3	3	
5	90206-06090	WASHER, WAVE	3	3	3	3	
6	3VD-14613-01	GASKET, EXHAUST PIPE	1	1	1	1	
7	90110-08097	BOLT, HEXAGON SOCKET HEAD	1	1	1	1	
8	2S2-14750-30	SILENCER ASSY	1			1	
9	90267-48084	.RIVET, BLIND	16	16	16	16	
10	2S2-1469A-00	.FIBER	1			1	
11	2S2-1469E-00	.FIBER	1	1	1	1	
12	2S2-1469F-00	.FIBER	1	1	1	1	
13	5VY-14714-00	.GASKET, MUFFLER	1	1	1	1	
14	5BE-14747-00	.DAMPER, MUFFLER	1	1	1	1	
15	90387-08081	.COLLAR	1	1	1	1	
16	2S2-14788-00	BAND, SILENCER	1	1	1	1	
17	90105-08307	BOLT, FLANGE	1	1	1	1	
18	90105-08137	BOLT, FLANGE	1	1	1	1	
19	90201-08061	WASHER, PLATE	1	1	1	1	

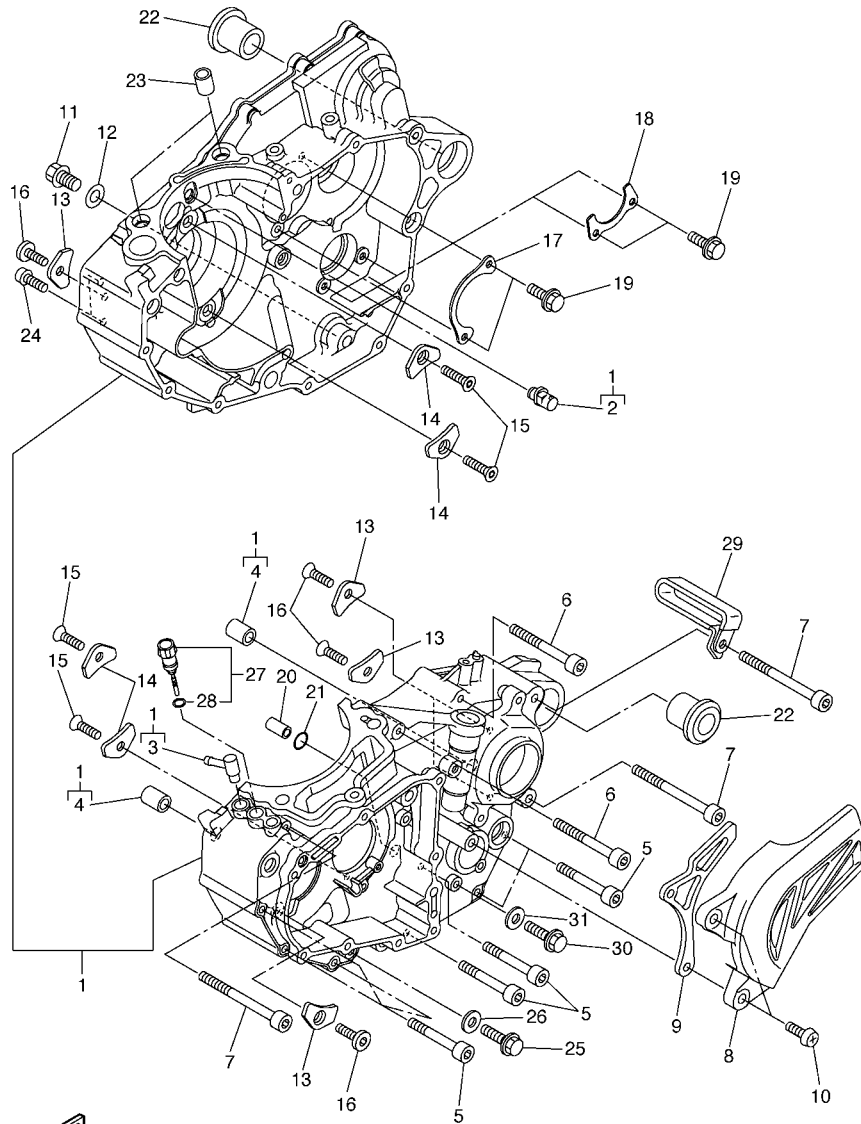

2S21100-E120

FIG. 12 CRANKCASE

REF. NO.	PART NO.	DESCRIPTION	2S27	2S28	2S29	2S2A	REMARKS
1	2S2-15100-00	CRANKCASE ASSY	1	1	1	1	
2	2S2-15155-00	.NOZZLE 3	1	1	1	1	
3	5XC-15373-00	.PIPE, BREATHER	1	1	1	1	
4	99530-14016	.PIN, DOWEL	2	2	2	2	
5	91312-06050	BOLT	7	7	7	7	
6	91312-06060	BOLT	2	2	2	2	
7	91312-06080	BOLT	3	3	3	3	
8	2S2-15421-00	COVER, CRANKCASE 2	1	1	1	1	
9	2S2-17466-00	GUIDE, CHAIN	1	1	1	1	
10	98502-06025	SCREW, PAN HEAD	2	2	2	2	
11	95022-10016	BOLT, FLANGE	1	1	1	1	
12	90430-10188	GASKET	1	1	1	1	
13	4JT-15381-01	PLATE, BEARING COVER	4	4	4	4	
14	5BE-15383-01	PLATE, BEARING COVER	4	4	4	4	
15	90151-06044	SCREW, COUNTERSUNK	4	4	4	4	
16	90149-06074	SCREW	4	4	4	4	
17	2S2-15388-00	PLATE, BEARING COVER	1	1	1	1	
18	2S2-18562-00	PLATE, STOPPER 2	1	1	1	1	
19	90105-06081	BOLT, FLANGE	4	4	4	4	
20	99530-10114	PIN, DOWEL	1	1	1	1	
21	93210-10197	O-RING	1	1	1	1	
22	90387-18007	COLLAR	2	2	2	2	
23	99530-14016	PIN, DOWEL	2	2	2	2	
24	91312-06030	BOLT	2	2	2	2	
25	95822-08016	BOLT, FLANGE	1	1	1	1	
26	90430-08119	GASKET	1	1	1	1	
27	2S2-1536A-00	PLUG, OIL LEVEL	1	1	1	1	

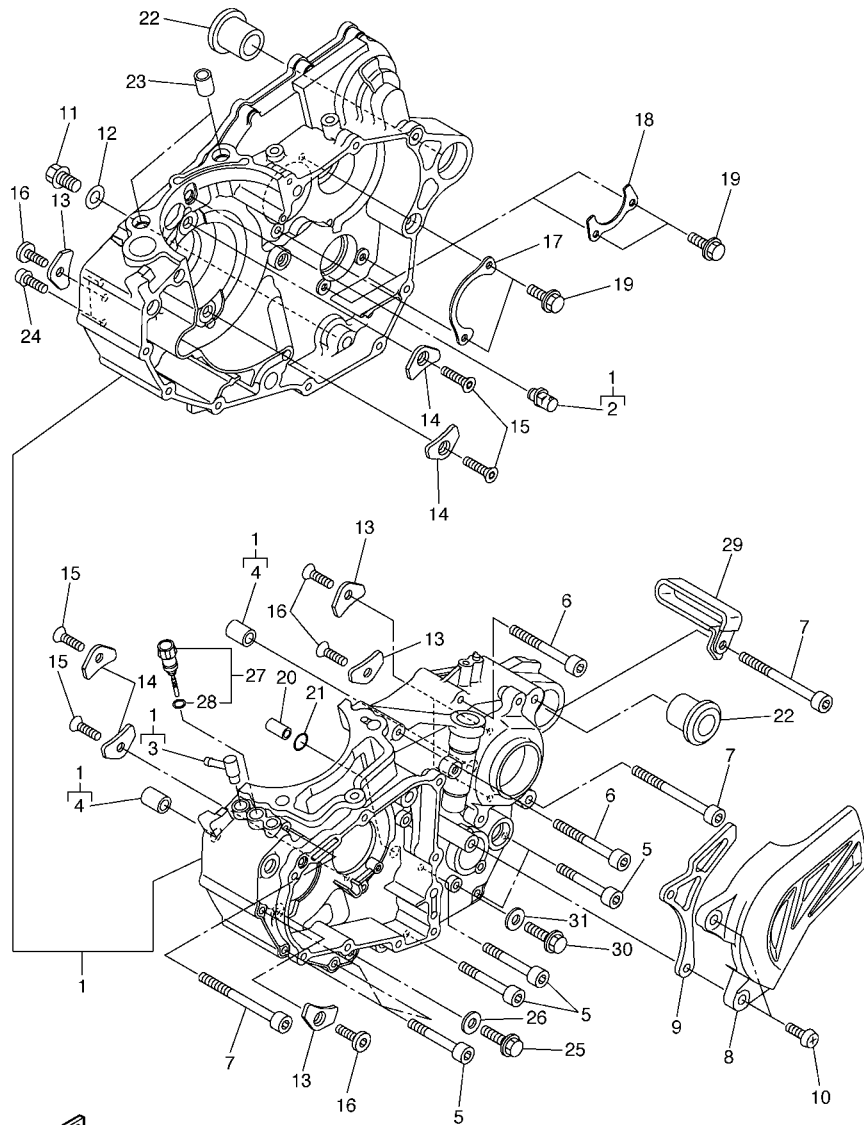

2S21100-E120

FIG. 12 CRANKCASE

REF. NO.	PART NO.	DESCRIPTION	2S27	2S28	2S29	2S2A	REMARKS
28	93210-09165	.O-RING	1	1	1	1	
29	90461-10136	CLAMP	1	1	1	1	
30	95022-06012	BOLT, FLANGE	1	1	1	1	
31	90430-06014	GASKET	1	1	1	1	

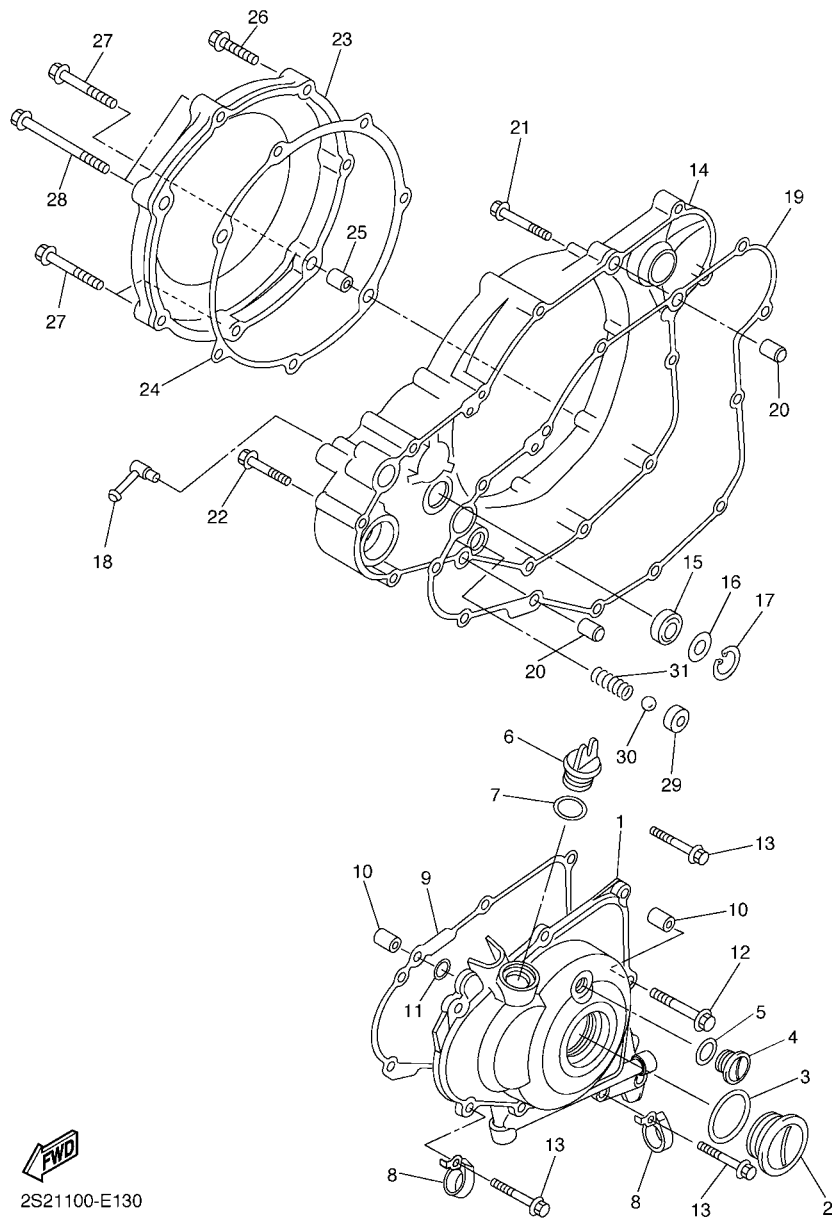

2S21100-E130

FIG. 13 CRANKCASE COVER 1

REF. NO.	PART NO.	DESCRIPTION	2S27	2S28	2S29	2S2A	REMARKS
1	2S2-15411-00	COVER, CRANKCASE 1	1	1	1	1	
2	90340-27002	PLUG, STRAIGHT SCREW	1	1	1	1	
3	93210-27370	O-RING	1	1	1	1	
4	90340-14128	PLUG, STRAIGHT SCREW	1	1	1	1	
5	93210-14369	O-RING	1	1	1	1	
6	3Y1-15363-00	PLUG, OIL	1	1	1	1	
7	93210-19123	O-RING	1	1	1	1	
8	2S2-15378-00	HOLDER	2	2	2	2	
9	2S2-15451-00	GASKET, CRANKCASE COVER 1	1	1	1	1	
10	99530-08016	PIN, DOWEL	2	2	2	2	
11	93210-08003	O-RING	1	1	1	1	
12	95022-06040	BOLT, FLANGE	1	1	1	1	
13	95022-06030	BOLT, FLANGE	7	7	7	7	
14	2S2-15431-00	COVER, CRANKCASE 3	1	1	1	1	
15	93101-14164	OIL SEAL	1	1	1	1	
16	90201-15701	WASHER, PLATE (T=1.0)	1	1	1	1	
17	99009-22500	CIRCLIP	1	1	1	1	
18	5XC-15373-00	PIPE, BREATHER	1	1	1	1	
19	2S2-15462-10	GASKET, CRANKCASE COVER 3	1	1	1	1	
20	91812-16001	PIN, DOWEL	2	2	2	2	
21	95022-06040	BOLT, FLANGE	2	2	2	2	
22	95022-06030	BOLT, FLANGE	6	6	6	6	
23	5TA-15415-10	COVER, GENERATOR	1	1	1	1	
24	5TA-15453-00	GASKET	1	1	1	1	
25	99530-08016	PIN, DOWEL	2	2	2	2	
26	95022-06030	BOLT, FLANGE	2	2	2	2	
27	95022-06040	BOLT, FLANGE	3	3	3	3	

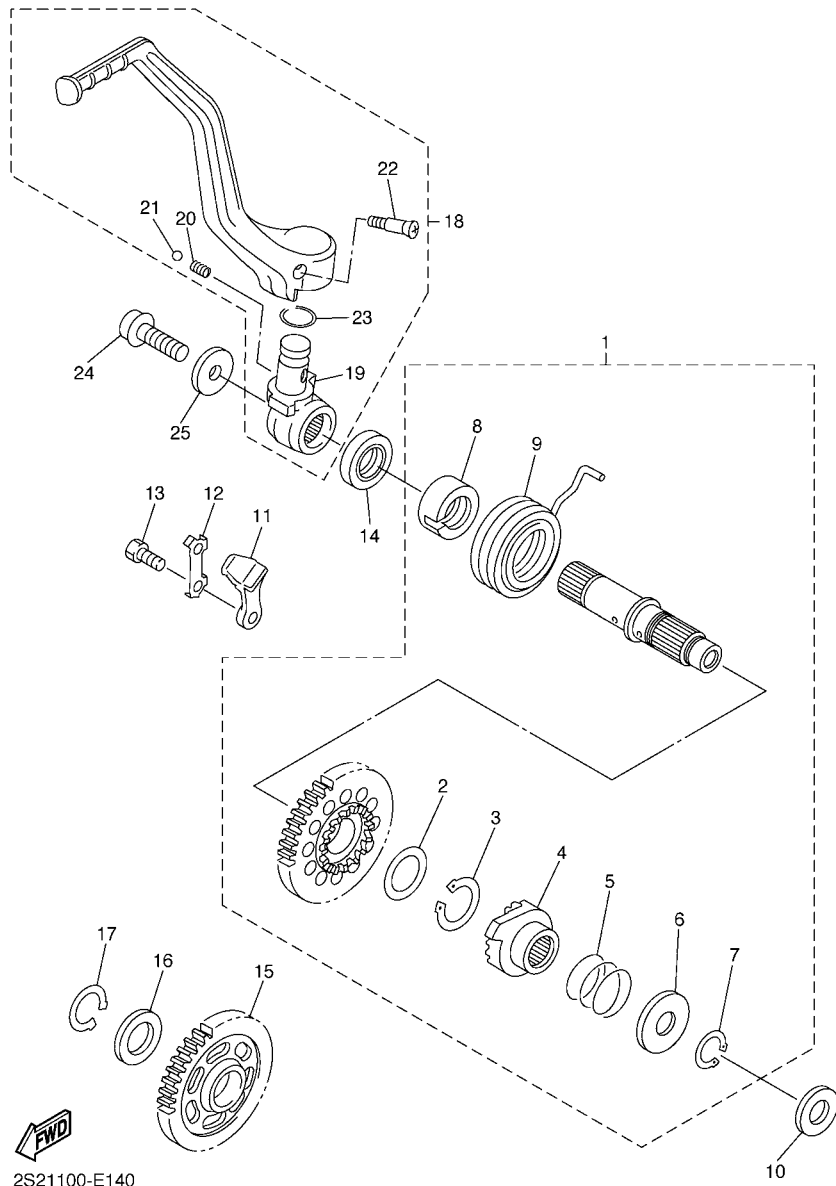
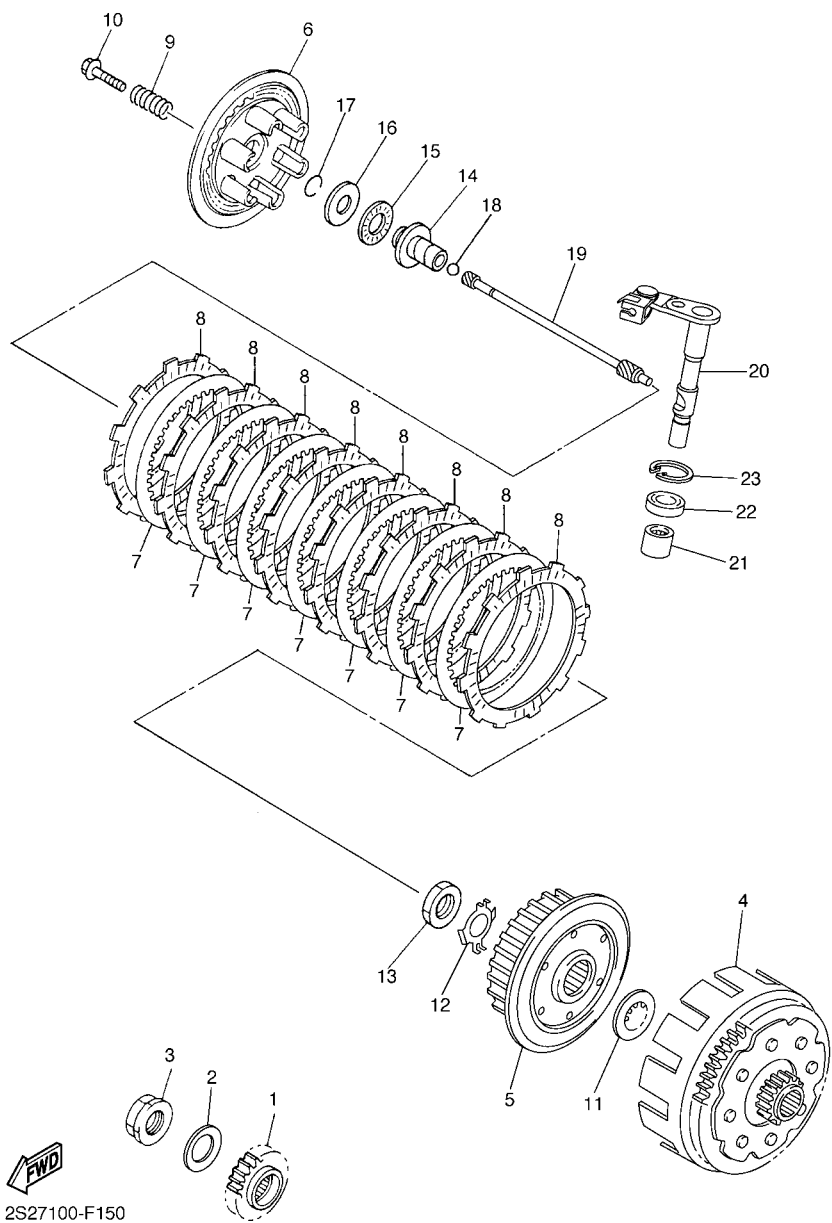

FIG. 14 STARTER

REF. NO.	PART NO.	DESCRIPTION	2S27	2S28	2S29	2S2A	REMARKS
1	2S2-15601-00	KICK SHAFT ASSY	1	1	1	1	
2	90201-20685	.WASHER, PLATE (T=0.5)	1	1	1	1	
3	93410-20038	.CIRCLIP	1	1	1	1	
4	2S2-15671-00	.WHEEL, RATCHET	1	1	1	1	
5	90501-160A2	.SPRING, COMPRESSION	1	1	1	1	
6	90201-167P7	.WASHER, PLATE	1	1	1	1	
7	99009-16400	.CIRCLIP	1	1	1	1	
8	5GR-15664-00	.GUIDE, SPRING	1	1	1	1	
9	90508-305B0	.SPRING, TORSION	1	1	1	1	
10	90201-162H4	WASHER, PLATE	1	1	1	1	
11	5SG-15668-00	STOPPER	1	1	1	1	
12	214-15686-00	WASHER, LOCK	1	1	1	1	
13	90101-06044	BOLT	2	2	2	2	
14	93102-20108	OIL SEAL	1	1	1	1	
15	5TA-15651-00	GEAR, KICK IDLE	1	1	1	1	
16	90201-20685	WASHER, PLATE (T=0.5)	1	1	1	1	
17	99009-20400	CIRCLIP	1	1	1	1	
18	2S2-15620-01	KICK CRANK ASSY	1	1	1	1	
19	5XD-15621-00	.BOSS, KICK CRANK	1	1	1	1	
20	90501-147A5	.SPRING, COMPRESSION	1	1	1	1	
21	93507-32009	.BALL	1	1	1	1	
22	90152-06010	.SCREW, COUNTERSUNK	1	1	1	1	
23	93210-17570	.O-RING	1	1	1	1	
24	90110-08087	BOLT, HEXAGON SOCKET HEAD	1	1	1	1	
25	90201-08047	WASHER, PLATE	1	1	1	1	

FIG. 15 CLUTCH



2S27100-F150

REF. NO.	PART NO.	DESCRIPTION	2S27	2S28	2S29	2S2A	REMARKS
1	2S2-16111-10	GEAR, PRIMARY DRIVE	1	1	1	1	
2	90208-25045	WASHER, CONICAL SPRING	1	1	1	1	
3	90179-20009	NUT	1	1	1	1	
4	5XD-16150-50	PRIMARY DRIVEN GEAR COMP.	1	1	1	1	
5	5TA-16371-10	BOSS, CLUTCH	1	1	1	1	
6	2S2-16351-00	PLATE, PRESSED 1	1	1	1	1	
7	4X7-16325-00	PLATE, CLUTCH 2	7	7	7	7	
8	5TA-16321-00	PLATE, FRICTION	8	8	8	8	
9	90501-230E4	SPRING, COMPRESSION	6	6	6	6	
10	90159-06010	SCREW, WITH WASHER	6	6	6	6	
11	5XD-16154-00	PLATE, THRUST 1	1	1	1	1	
12	90215-20005	WASHER, LOCK	1	1	1	1	
13	90170-20327	NUT	1	1	1	1	
14	5JG-16356-00	ROD, PUSH 1	1	1	1	1	
15	93340-21505	BEARING	1	1	1	1	
16	90201-125L6	WASHER, PLATE	1	1	1	1	
17	93440-10085	CIRCLIP	1	1	1	1	
18	93511-32027	BALL	1	1	1	1	
19	2S2-16357-00	ROD, PUSH 2	1	1	1	1	
20	2S2-16380-10	PUSH LEVER ASSY	1	1	1	1	
21	93317-11287	BEARING	1	1	1	1	
22	93102-12224	OIL SEAL	1	1	1	1	
23	99009-20500	CIRCLIP	1	1	1	1	

FIG. 16 TRANSMISSION

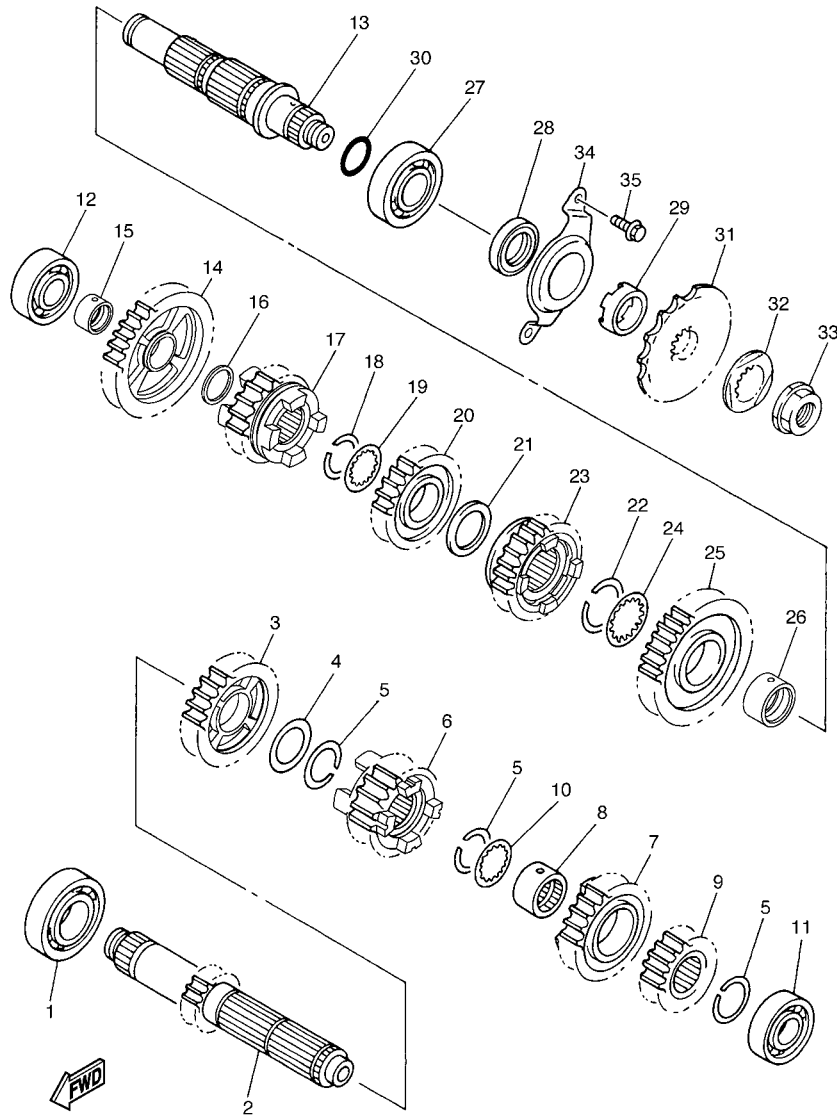

2S21100-E160

REF. NO.	PART NO.	DESCRIPTION	2S27	2S28	2S29	2S2A	REMARKS
1	93306-20532	BEARING	1	1	1	1	
2	2S2-17411-00	AXLE,MAIN(14T)	1	1	1	1	
3	2S2-17151-00	GEAR, 5TH PINION(21T)	1	1	1	1	
4	90201-253K0	WASHER, PLATE (T=1.0)	1	1	1	1	
5	93440-25084	CIRCLIP	3	3	3	3	
6	2S2-17131-00	GEAR, 3RD PINION(18T)	1	1	1	1	
7	2S2-17141-00	GEAR, 4TH PINION (22T)	1	1	1	1	
8	90387-21005	COLLAR	1	1	1	1	
9	2S2-17121-00	GEAR, 2ND PINION(15T)	1	1	1	1	
10	90209-21332	WASHER	1	1	1	1	
11	93306-00431	BEARING	1	1	1	1	
12	93306-00426	BEARING	1	1	1	1	
13	2S2-17402-00	DRIVE AXLE ASSY	1	1	1	1	
14	2S2-17211-00	GEAR, 1ST WHEEL(27T)	1	1	1	1	
15	90387-20028	COLLAR	1	1	1	1	
16	90201-203E7	WASHER, PLATE	1	1	1	1	
17	2S2-17251-00	GEAR, 5TH WHEEL(20T)	1	1	1	1	
18	93440-25084	CIRCLIP	1	1	1	1	
19	90209-21332	WASHER	1	1	1	1	
20	2S2-17231-00	GEAR, 3RD WHEEL(23T)	1	1	1	1	
21	90201-253K0	WASHER, PLATE (T=1.0)	1	1	1	1	
22	93440-28062	CIRCLIP	1	1	1	1	
23	2S2-17241-00	GEAR, 4TH WHEEL(24T)	1	1	1	1	
24	90209-26348	WASHER	1	1	1	1	
25	2S2-17221-00	GEAR, 2ND WHEEL(23T)	1	1	1	1	
26	90387-28012	COLLAR	1	1	1	1	
27	93306-205A5	BEARING	1	1	1	1	

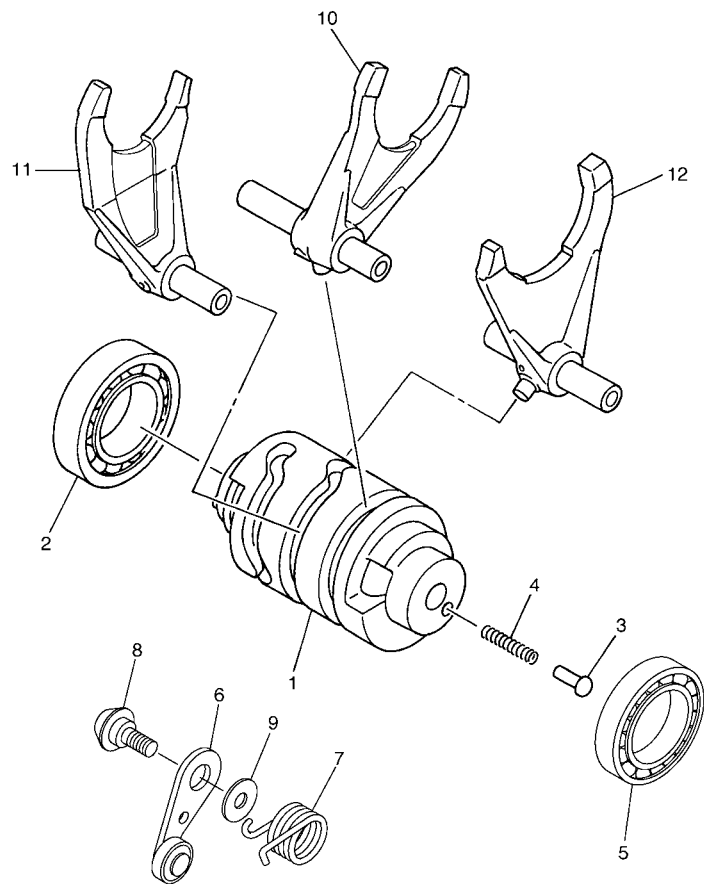

2S27100-F170

FIG. 17 SHIFT CAM & FORK

REF. NO.	PART NO.	DESCRIPTION	2S27	2S28	2S29	2S2A	REMARKS
1	5NL-18541-00	CAM, SHIFT	1	1	1	1	
2	93306-90509	BEARING	1	1	1	1	
3	278-18542-00	POINT, NEUTRAL	1	1	1	1	
4	90501-06022	SPRING, COMPRESSION	1	1	1	1	
5	93306-80501	BEARING	1	1	1	1	
6	2S2-18140-10	STOPPER LEVER ASSY	1	1	1	1	
7	90508-26021	SPRING, TORSION	1	1	1	1	
8	90109-06198	BOLT	1	1	1	1	
9	90201-06013	WASHER, PLATE	1	1	1	1	
10	2S2-18501-00	FORK, SHIFT 1	1	1	1	1	
11	2S2-18502-00	FORK, SHIFT 2	1	1	1	1	
12	5BE-18503-00	FORK, SHIFT 3	1	1	1	1	

FIG. 18 SHIFT SHAFT

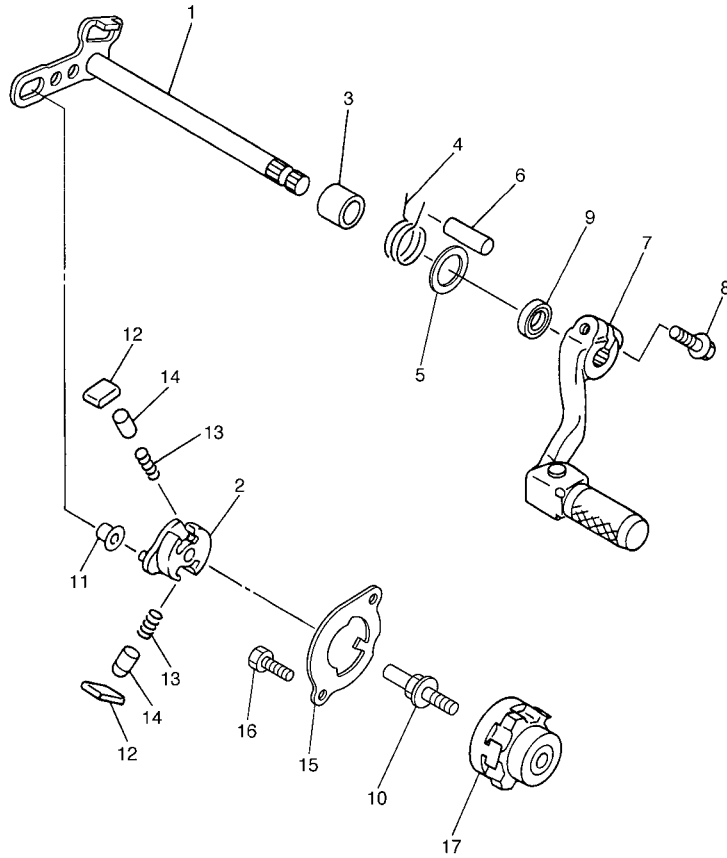

REF. NO.	PART NO.	DESCRIPTION	2S27	2S28	2S29	2S2A	REMARKS
1	2S2-18101-00	SHIFT SHAFT ASSY	1	1	1	1	
2	5MW-18122-01	LEVER, SHIFT 2	1	1	1	1	
3	90387-124F4	COLLAR	1	1	1	1	
4	90508-29021	SPRING, TORSION	1	1	1	1	
5	90201-127E1	WASHER, PLATE	1	1	1	1	
6	93608-33002	PIN, DOWEL	1	1	1	1	
7	2S2-18110-00	SHIFT PEDAL ASSY	1	1	1	1	
8	95022-06020	BOLT, FLANGE	1	1	1	1	
9	93102-12224	OIL SEAL	1	1	1	1	
10	3XJ-18173-10	PIN, SHIFT	1	1	1	1	
11	3XJ-18178-00	ROLLER, SHIFT LEVER	1	1	1	1	
12	3XJ-18182-00	PAWL, SHIFTER	2	2	2	2	
13	90501-052G5	SPRING, COMPRESSION	2	2	2	2	
14	3XJ-18184-00	PIN, PAWL	2	2	2	2	
15	5TJ-18172-00	GUIDE, SHIFT	1	1	1	1	
16	90101-06041	BOLT	2	2	2	2	
17	2S2-18185-00	SEGMENT	1	1	1	1	



2S21100-E180

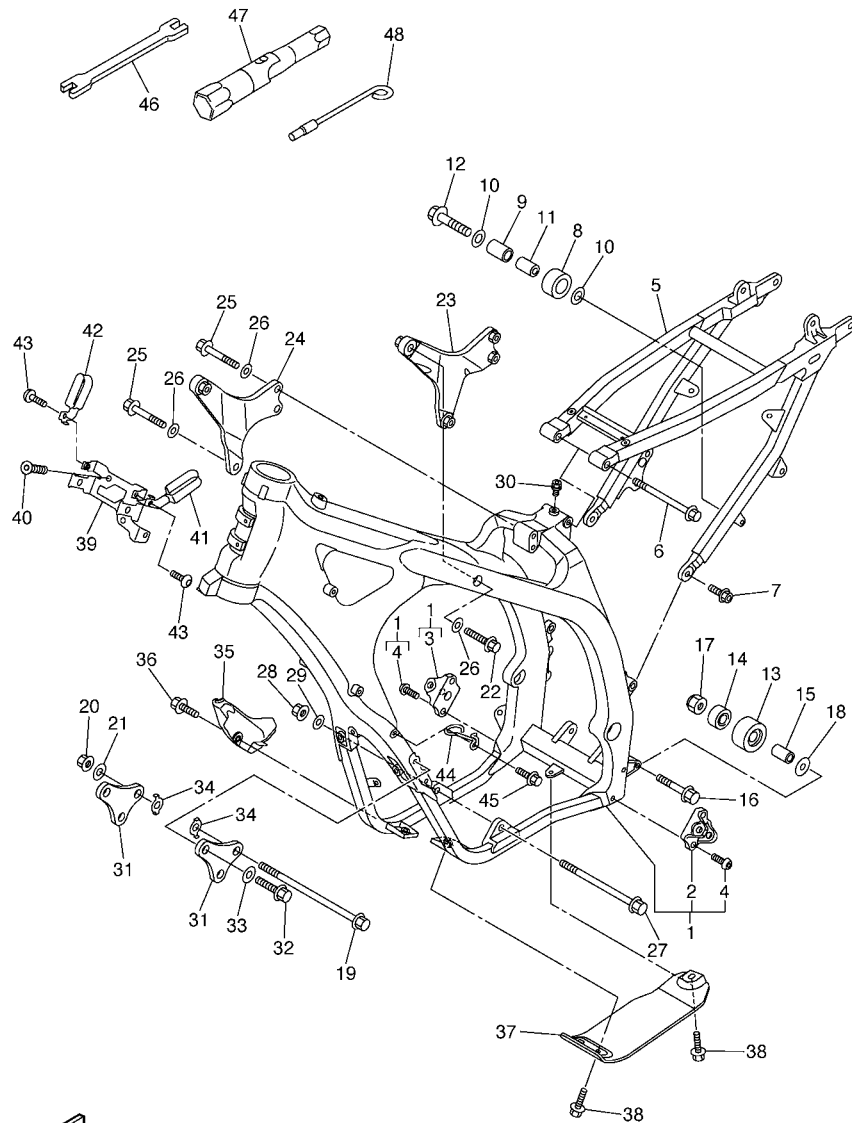

2S27100-F190

FIG. 19 FRAME

REF. NO.	PART NO.	DESCRIPTION	2S27	2S28	2S29	2S2A	REMARKS
1	2S2-21101-00	FRONT FRAME COMP.	1	1	1	1	
2	1C3-21447-10	.BRACKET, FOOTREST	1	1	1	1	
3	1C3-21448-10	.BRACKET, FOOTREST	1	1	1	1	
4	90149-10031	.SCREW	4	4	4	4	
5	2S2-21190-70	REAR FRAME COMP.	1	1	1	1	
6	90105-08156	BOLT, FLANGE	1	1	1	1	
7	90105-08307	BOLT, FLANGE	2	2	2	2	
8	30X-22178-00	TENSIONER	1	1	1	1	
9	4V4-22184-00	BUSH	1	1	1	1	
10	90201-08045	WASHER, PLATE	2	2	2	2	
11	90387-08041	COLLAR	1	1	1	1	
12	95022-08040	BOLT, FLANGE	1	1	1	1	
13	3JD-22178-20	TENSIONER	1	1	1	1	
14	93300-60839	BEARING	1	1	1	1	
15	90387-086N4	COLLAR	1	1	1	1	
16	90105-08146	BOLT, FLANGE	1	1	1	1	
17	90185-08009	NUT, SELF-LOCKING	1	1	1	1	
18	90201-08043	WASHER, PLATE	1	1	1	1	
19	90105-10193	BOLT, FLANGE	1	1	1	1	
20	90179-10658	NUT	1	1	1	1	
21	90201-10045	WASHER, PLATE	1	1	1	1	
22	90105-10189	BOLT, FLANGE	2	2	2	2	
23	2S2-21425-70	BRACKET, REAR UPPER 1	1	1	1	1	
24	2S2-21426-70	BRACKET, REAR UPPER 2	1	1	1	1	
25	90105-10191	BOLT, FLANGE	3	3	3	3	
26	90201-10045	WASHER, PLATE	5	5	5	5	
27	90105-10176	BOLT, FLANGE	1	1	1	1	

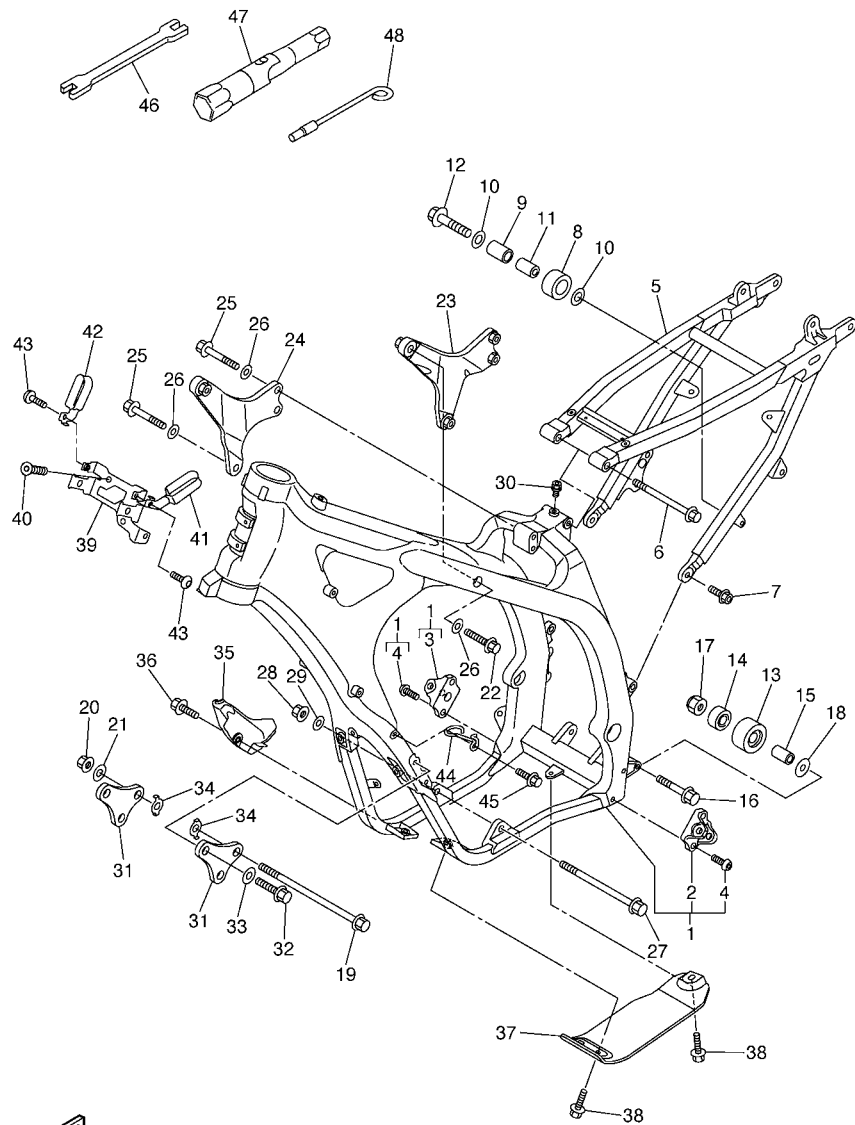

2S27100-F190

FIG. 19 FRAME

REF. NO.	PART NO.	DESCRIPTION	2S27	2S28	2S29	2S2A	REMARKS
28	90179-10658	NUT	1	1	1	1	
29	90201-10045	WASHER, PLATE	1	1	1	1	
30	1C3-21244-10	NUT	1	1	1	1	
31	2S2-21417-00	BRACKET, FRONT LOWER 1	2	2	2	2	
32	90105-08143	BOLT, FLANGE	4	4	4	4	
33	92902-08200	WASHER	4	4	4	4	
34	5XC-21456-90	PLATE, PATCH	2	2	2	2	
35	2S2-21471-00	PROTECTOR, ENGINE	1	1	1	1	
36	90119-06146	BOLT, WITH WASHER	1	1	1	1	
37	2S2-2147E-00	GUARD, ENGINE 2	1	1	1	1	
38	90119-06146	BOLT, WITH WASHER	3	3	3	3	
39	5XC-21274-90	BRACKET, C.D.I. UNIT	1	1	1	1	
40	90151-06032	SCREW, COUNTERSUNK	2	2	2	2	
41	2S2-21163-70	HOLDER, CLUTCH CABLE	1	1	1	1	
42	5XC-21164-90	HOLDER, CABLE	1	1	1	1	
43	92012-05008	BOLT, BUTTON HEAD	2	2	2	2	
44	5XC-21288-90	GUIDE, CABLE	1	1	1	1	
45	90105-05014	BOLT, FLANGE	1	1	1	1	
46	5ET-28166-10	WRENCH, HEXAGON	1	1	1	1	
47	5TA-2814F-00	BOX, SPARK PLUG	1	1	1	1	
48	5XC-28116-00	TOOL, SPECIAL	1	1	1	1	

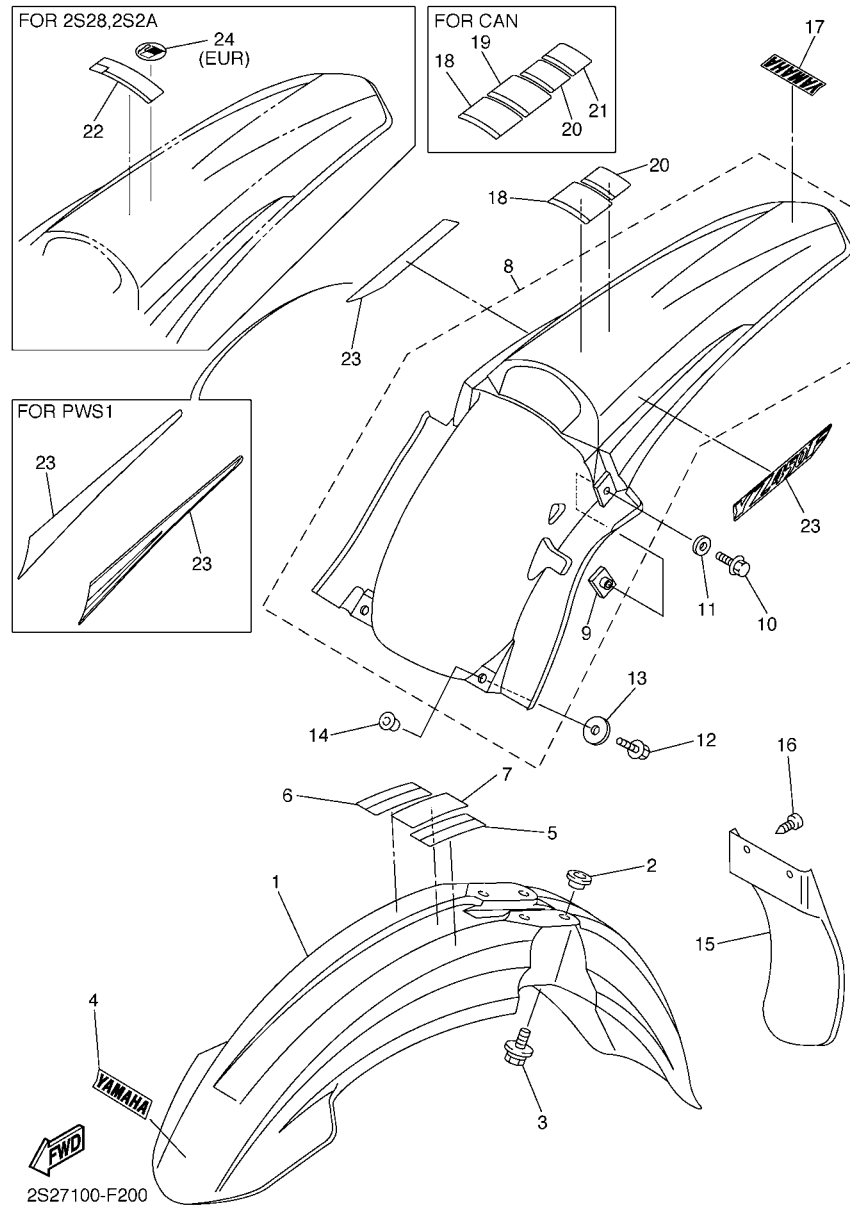
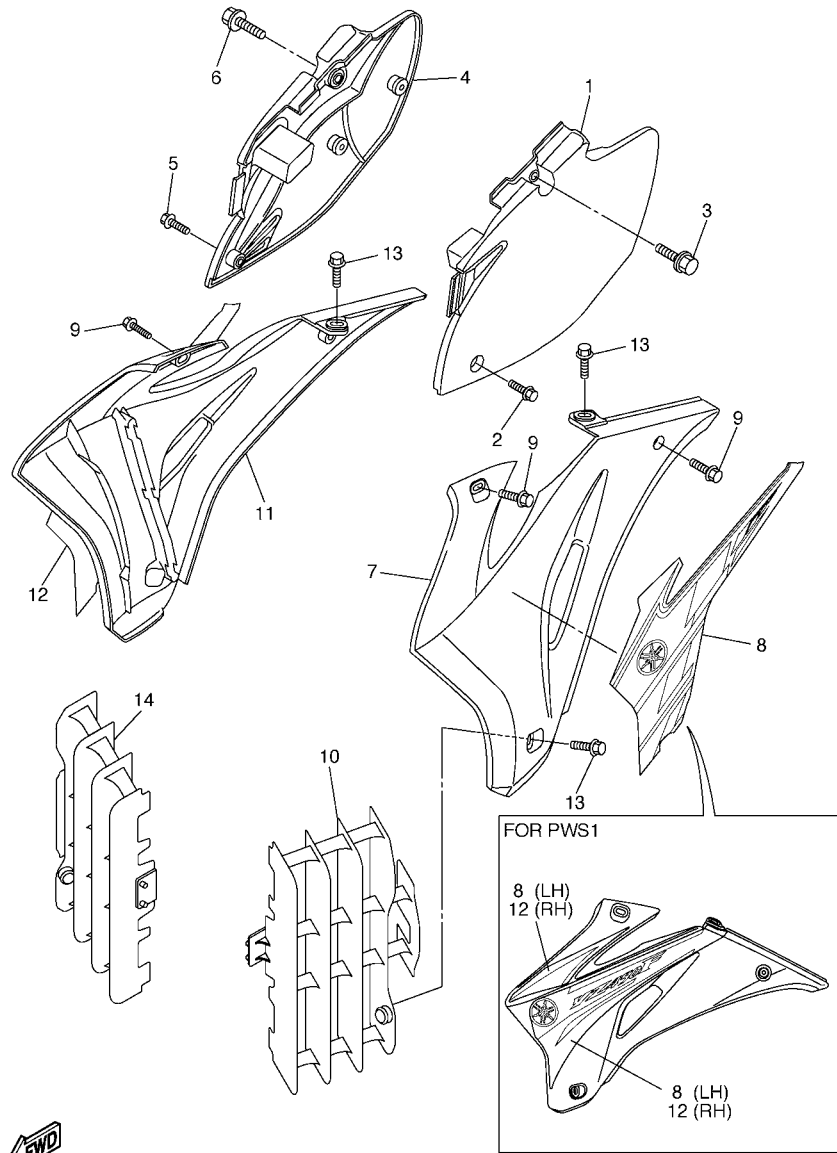

FIG. 20 FENDER

REF. NO.	PART NO.	DESCRIPTION	2S27	2S28	2S29	2S2A	REMARKS
1	1C3-21511-51	FENDER, FRONT	1	1	1	1	UR FOR DPBSE
	2S2-21511-70	FENDER, FRONT	1	1		1	UR FOR PWS1
2	90387-06090	COLLAR	4	4	4	4	
3	90119-06147	BOLT, WITH WASHER	4	4	4	4	
4	4ES-2153E-01	EMBLEM, YAMAHA	1	1	1	1	UR FOR DPBSE
	4ES-2153E-20	EMBLEM, YAMAHA	1	1		1	UR FOR PWS1
5	N/A						
6	N/A						
7	N/A						
8	5XC-21610-90	REAR FENDER COMP.	1	1	1	1	UR FOR DPBSE
	2S2-21610-70	REAR FENDER COMP.	1	1		1	UR FOR PWS1
9	5XE-21635-10	.NUT, REAR FENDER	2	2	2	2	
10	90105-06100	BOLT, FLANGE	2	2	2	2	
11	90201-06032	WASHER, PLATE	2	2	2	2	
12	90105-06106	BOLT, FLANGE	2	2	2	2	
13	90201-06571	WASHER, PLATE	2	2	2	2	
14	90387-06009	COLLAR	2	2	2	2	
15	5TA-21642-00	GUARD, FLAP	1	1	1	1	
16	97702-60016	SCREW, TAPPING	2	2	2	2	
17	5XC-2153E-00	EMBLEM, YAMAHA	1	1	1	1	UR FOR DPBSE
	5XC-2153E-10	EMBLEM, YAMAHA	1	1		1	UR FOR PWS1
18	N/A						
19	N/A						
20	3XJ-2151H-A1	LABEL 5	1				



2S27100-F210

FIG. 21 SIDE COVER

REF. NO.	PART NO.	DESCRIPTION	2S27	2S28	2S29	2S2A	REMARKS
1	5XC-21710-90	SIDE COVER ASSY 1	1	1	1	1	
2	90105-06103	BOLT, FLANGE	1	1	1	1	
3	90119-08095	BOLT, WITH WASHER	1	1	1	1	
4	5XC-21720-90	SIDE COVER ASSY 2	1	1	1	1	
5	90105-06103	BOLT, FLANGE	1	1	1	1	
6	90119-08095	BOLT, WITH WASHER	1	1	1	1	
7	5XC-21730-90	SIDE COVER ASSY 3	1	1	1	1	UR FOR DPBSE
	2S2-21730-70	SIDE COVER ASSY 3	1	1		1	UR FOR PWS1
8	5XC-2173E-10	GRAPHIC 1	1	1	1	1	UR FOR DPBSE
	2S2-2173L-00	GRAPHIC SET 1	1	1		1	UR FOR PWS1
9	90105-06064	BOLT, FLANGE	4	4	4	4	
10	2S2-2172A-70	PANEL 1	1	1	1	1	
11	5XC-21740-90	SIDE COVER ASSY 4	1	1	1	1	UR FOR DPBSE
	2S2-21740-70	SIDE COVER ASSY 4	1	1		1	UR FOR PWS1
12	5XC-2173F-10	GRAPHIC 2	1	1	1	1	UR FOR DPBSE
	2S2-2174L-00	GRAPHIC SET 2	1	1		1	UR FOR PWS1
13	90105-06064	BOLT, FLANGE	4	4	4	4	
14	2S2-2172A-80	PANEL 1	1	1	1	1	

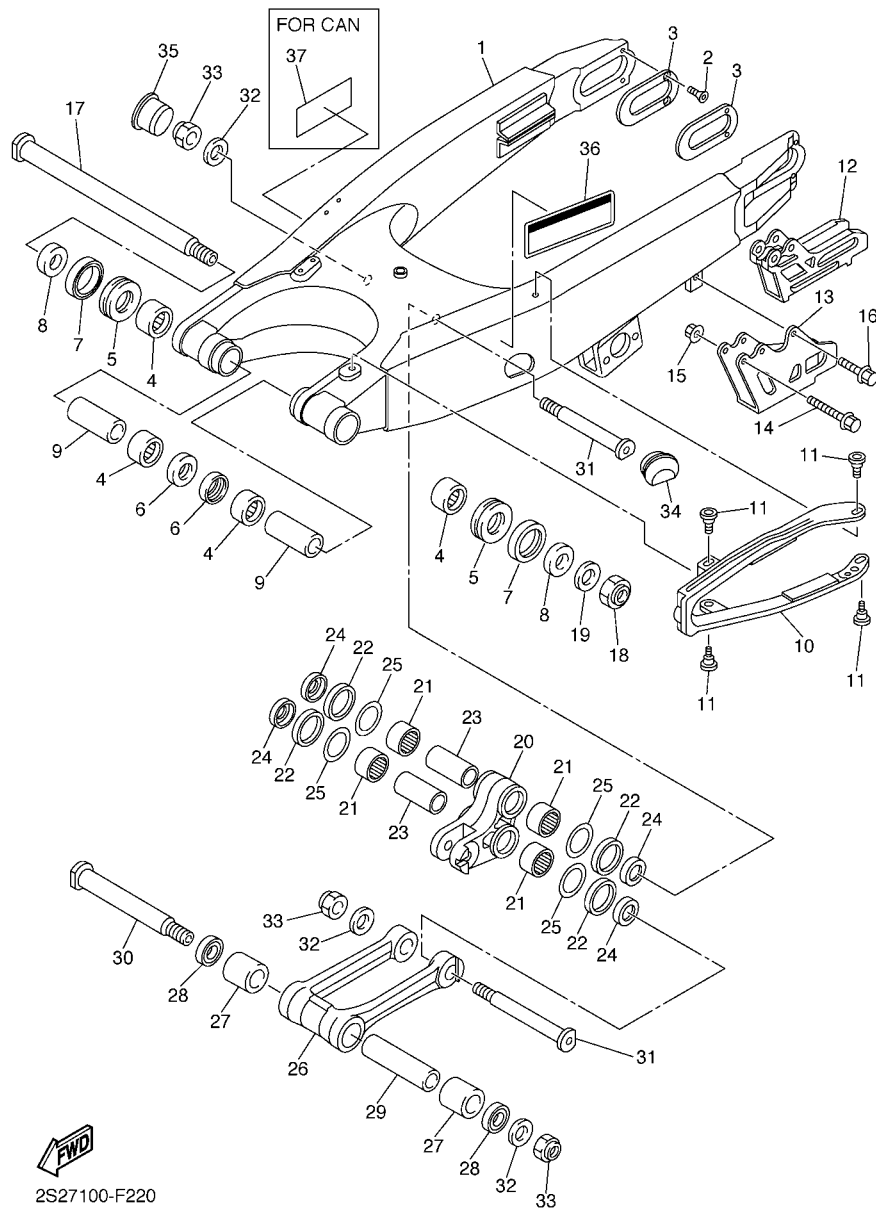

2S27100-F220

FIG. 22 REAR ARM

REF. NO.	PART NO.	DESCRIPTION	2S27	2S28	2S29	2S2A	REMARKS
1	2S2-22110-70	REAR ARM COMP.	1	1	1	1	
2	90151-04003	SCREW, COUNTERSUNK	4	4	4	4	
3	1P8-22355-00	PATCH	2	2	2	2	
4	93317-22262	BEARING	4	4	4	4	
5	93342-22217	BEARING	2	2	2	2	
6	93106-22002	OIL SEAL	2	2	2	2	
7	93109-28043	OIL SEAL	2	2	2	2	
8	90387-18012	COLLAR	2	2	2	2	
9	90387-18004	COLLAR	2	2	2	2	
10	2S2-22151-70	SEAL, GUARD	1	1	1	1	
11	1C3-22969-90	SCREW, 1	4	4	4	4	
12	2S2-22199-70	SUPPORT, CHAIN	1	1	1	1	
13	2S2-22128-70	COVER, THRUST 1	1	1	1	1	
14	90105-06104	BOLT, FLANGE	2	2	2	2	
15	90179-06028	NUT	2	2	2	2	
16	90105-06105	BOLT, FLANGE	1	1	1	1	
17	1C3-22141-10	SHAFT, PIVOT	1	1	1	1	
18	90185-16002	NUT, SELF-LOCKING	1	1	1	1	
19	90201-16018	WASHER, PLATE	1	1	1	1	
20	5XC-2217A-90	ARM, RELAY	1	1	1	1	
21	93315-32166	BEARING	4	4	4	4	
22	93109-25001	OIL SEAL	4	4	4	4	
23	90387-16010	COLLAR	2	2	2	2	
24	90209-16011	WASHER	4	4	4	4	
25	90201-21014	WASHER, PLATE	4	4	4	4	
26	5XC-2217F-90	ROD, CONNECTING 1	1	1	1	1	
27	93315-32269	BEARING	2	2	2	2	

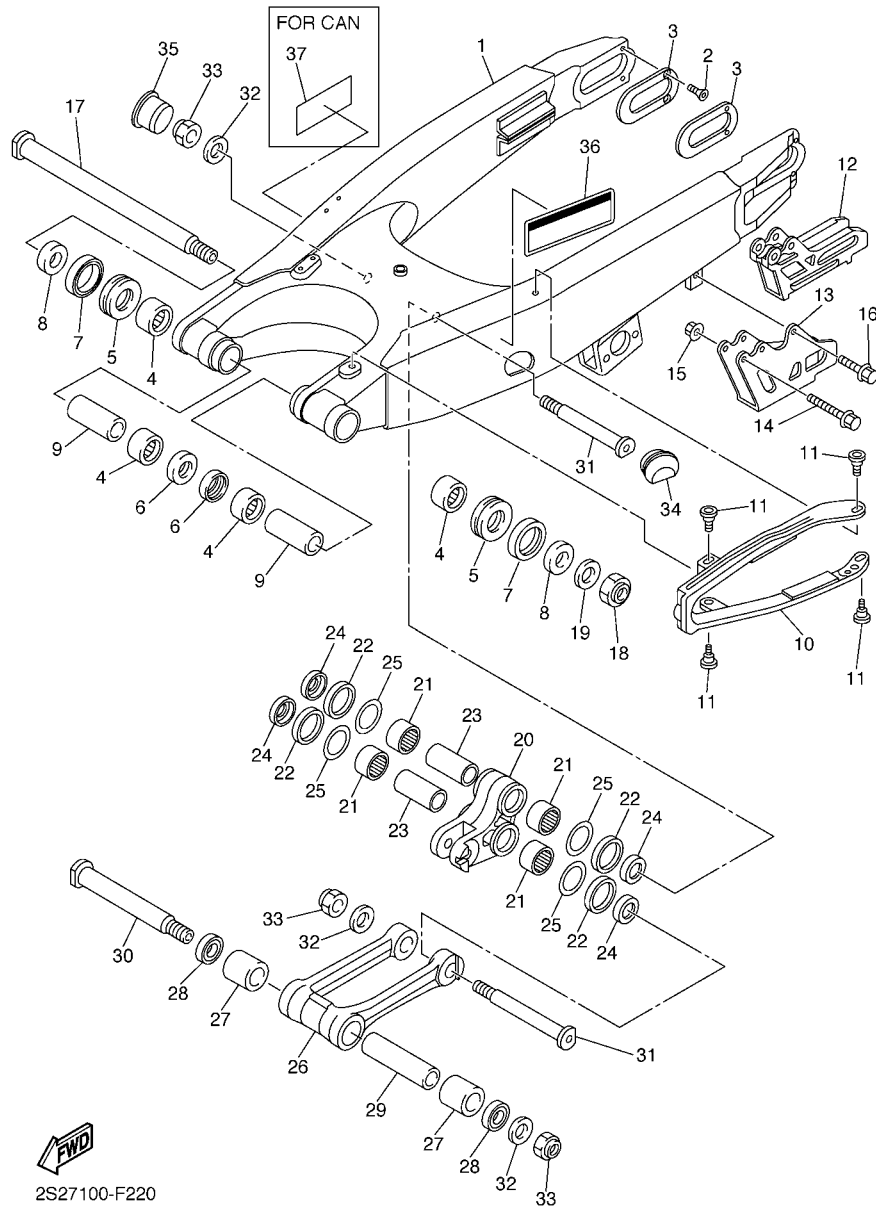

2S27100-F220

FIG. 22 REAR ARM

REF. NO.	PART NO.	DESCRIPTION	2S27	2S28	2S29	2S2A	REMARKS
28	93109-22019	OIL SEAL	2	2	2	2	
29	90387-14009	COLLAR	1	1	1	1	
30	5XC-22121-91	SHAFT 1	1	1	1	1	
31	1C3-22122-00	SHAFT 2	2	2	2	2	
32	90201-14020	WASHER, PLATE	3	3	3	3	
33	90185-14010	NUT, SELF-LOCKING	3	3	3	3	
34	1C3-2135F-00	COVER	1	1	1	1	
35	1C3-2139R-00	COVER 2	1	1	1	1	
36	3RV-21668-A0	LABEL, TIRE	1	1		1	
37	N/A						

FIG. 23 REAR SUSPENSION

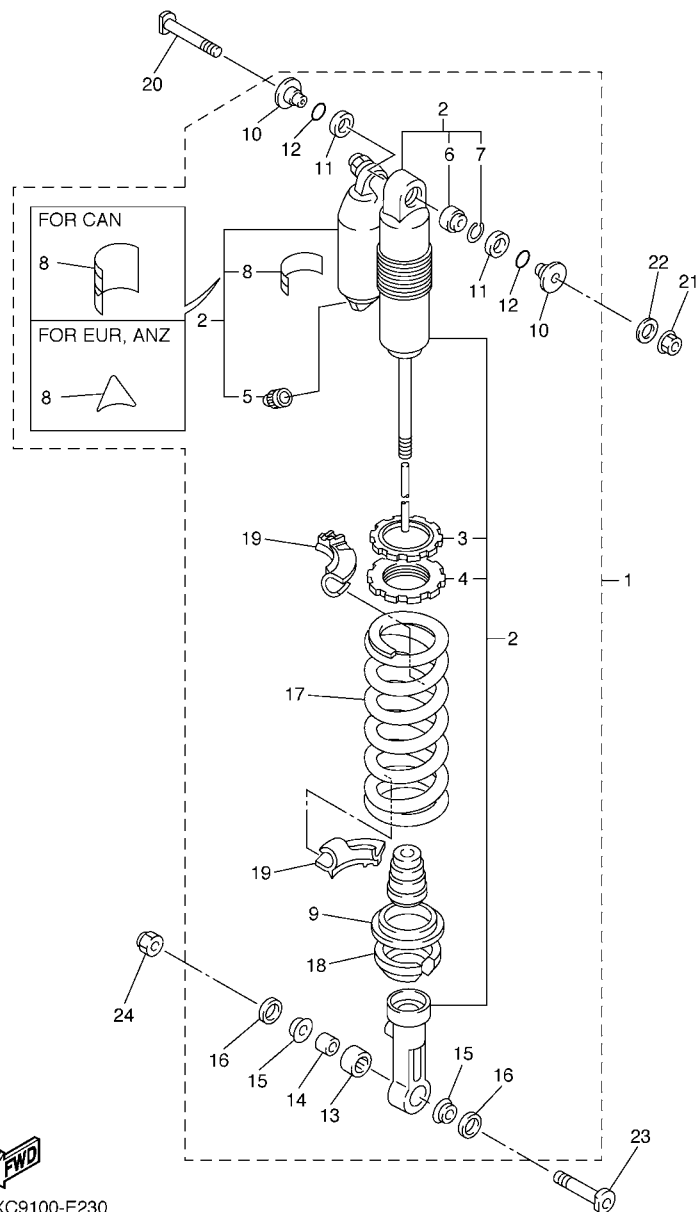

FWD
5XC9100-E230

REF. NO.	PART NO.	DESCRIPTION	2S27	2S28	2S29	2S2A	REMARKS
1	2S2-22200-80	SHOCK ABSORBER ASSY, REAR				1	
2	2S2-22201-50	.DAMPER SUB ASSY	1		1	1	
3	3SP-22234-00	..GUIDE, SPRING 3	1	1	1	1	
4	1C3-22213-L0	..SEAT, SPRING UPPER	1	1	1	1	
5	509-23184-L0	..CAP, AIR VALVE	1	1	1	1	
6	4JX-22226-00	..BUSH, SHOCK ABSORBER LOWER	1	1	1	1	
7	5DH-23183-00	..CIRCLIP	1	1	1	1	
8	4AA-22259-40	..LABEL, WARNING				1	
9	5MV-22224-00	.GUIDE, SPRING 2	1	1	1	1	
10	1C3-22253-50	.COLLAR, DISTANCE	2	2	2	2	
11	3JE-22475-00	.SEAL, DUST	2	2	2	2	
12	4EW-22474-00	.SEAL, RING	2	2	2	2	
13	5UN-22176-00	.BEARING	1	1	1	1	
14	5MV-22184-00	.BUSH	1	1	1	1	
15	1C3-22253-L0	.COLLAR, DISTANCE	2	2	2	2	
16	5NY-22475-00	.SEAL, DUST	2	2	2	2	
17	1C3-22212-50	.SPRING (K=54N/MM)	1	1	1	1	
18	1C3-22214-50	.GUIDE, SPRING 1	1	1	1	1	
19	1C3-22565-00	.SPRING SEAT	2	2	2	2	

FIG. 24 STEERING

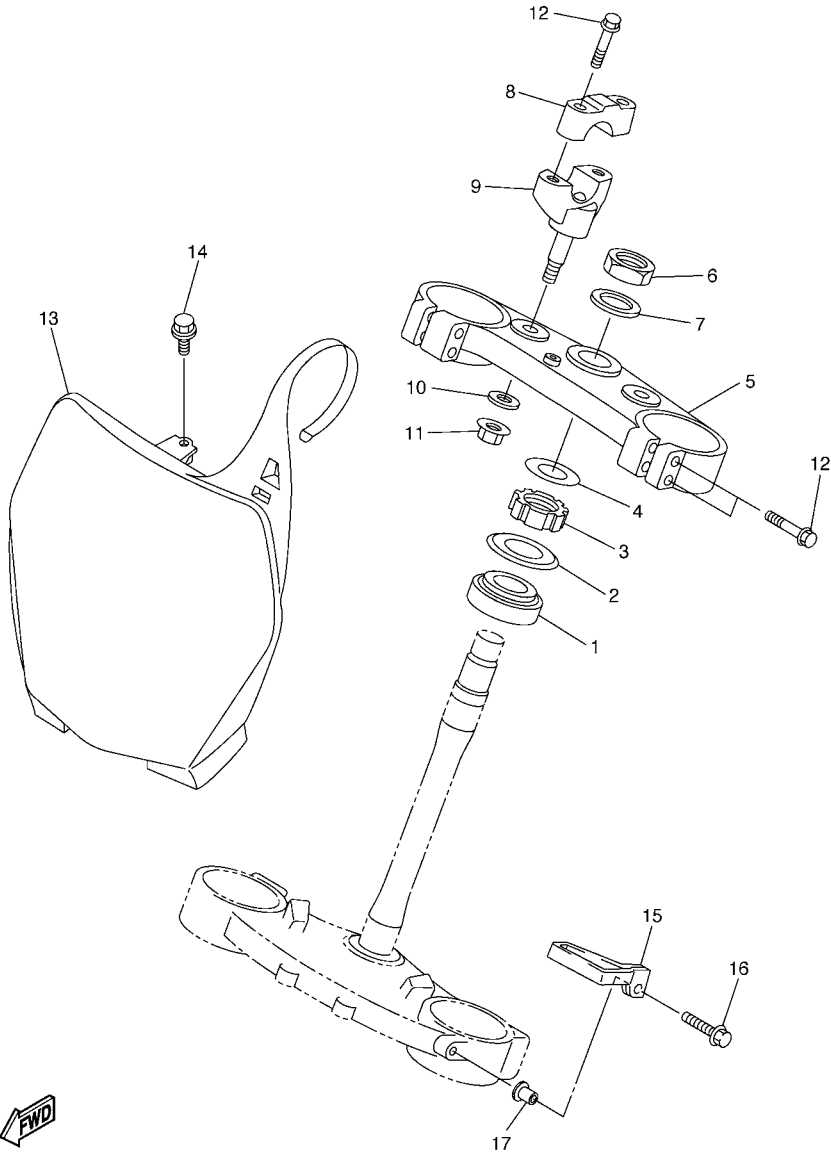

REF. NO.	PART NO.	DESCRIPTION	2S27	2S28	2S29	2S2A	REMARKS
1	93332-00068	BEARING	1	1	1	1	
2	4EW-23416-00	COVER, BALL RACE 2	1	1	1	1	
3	90179-28003	NUT	1	1	1	1	
4	90201-286K9	WASHER, PLATE	1	1	1	1	
5	2S2-23435-70	CROWN, HANDLE	1	1	1	1	
6	90170-24003	NUT	1	1	1	1	
7	90201-24016	WASHER, PLATE	1	1	1	1	
8	5XC-23441-90	HOLDER, HANDLE UPPER	2	2	2	2	
9	2S2-23442-70	HOLDER, HANDLE LOWER	2	2	2	2	
10	92902-10200	WASHER	2	2	2	2	
11	95602-10200	NUT, U FLANGE	2	2	2	2	
12	90105-08154	BOLT, FLANGE	8	8	8	8	
13	1C3-23485-70	PLATE, NUMBER	1	1	1	1	
14	90119-06146	BOLT, WITH WASHER	1	1	1	1	
15	5XE-23389-00	GUIDE, CABLE	1	1	1	1	
16	90105-06107	BOLT, FLANGE	1	1	1	1	
17	90387-06104	COLLAR	1	1	1	1	



2S27100-F240

D9

FIG. 25 FRONT FORK

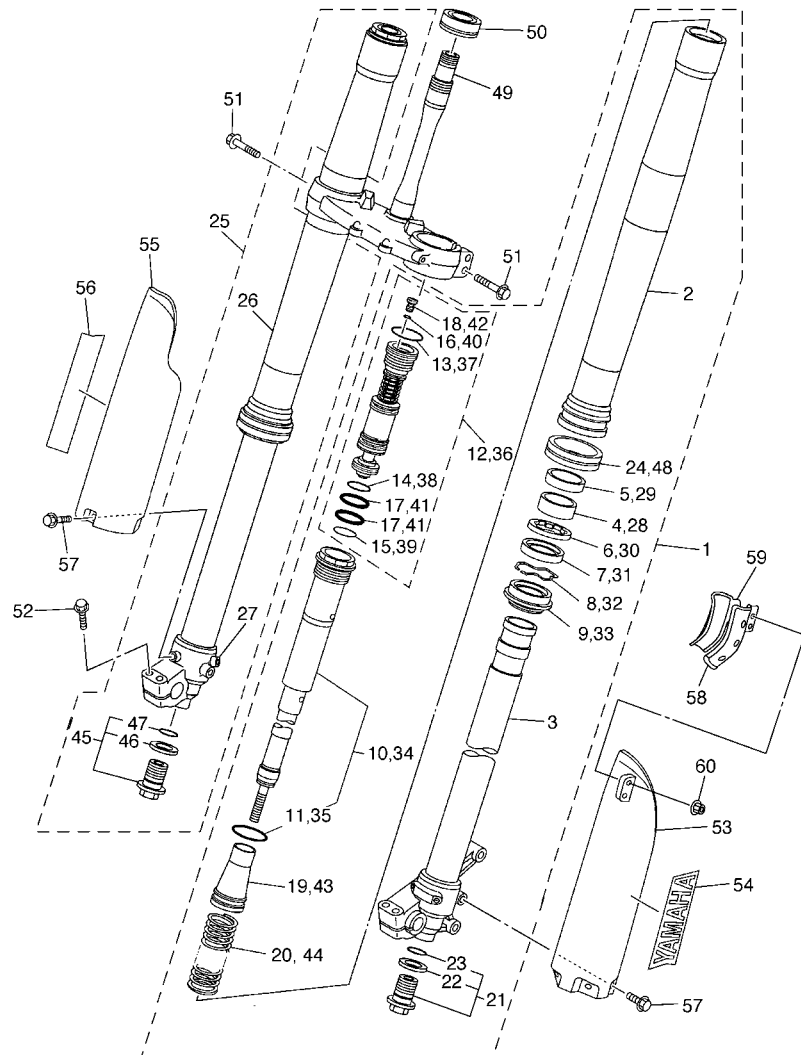

REF. NO.	PART NO.	DESCRIPTION	2S27	2S28	2S29	2S2A	REMARKS
1	2S2-23102-50	FRONT FORK ASSY (L.H)	1		1	1	
2	1C3-23136-M0	.TUBE, OUTER (RIGHT)	1	1	1	1	
3	1C3-23120-M0	.INNER TUBE COMP.2	1	1	1	1	
4	5XE-23171-L0	.PISTON, FRONT FORK	1	1	1	1	
5	5XE-23125-L0	.METAL, SLIDE 1	1	1	1	1	
6	5XE-23146-L0	.WASHER, OIL SEAL	1	1	1	1	
7	1C3-23145-M0	.OIL SEAL	1	1	1	1	
8	5XE-23153-L0	.RING, SNAP	1	1	1	1	
9	5XE-23144-L0	.SEAL, DUST	1	1	1	1	
10	1C3-23170-R0	.CYLINDER COMP., FRONT FORK	1	1	1	1	
11	1C3-23147-L0	..O-RING	1	1	1	1	
12	1C3-2316A-R0	.VALVE COMP.	1	1	1	1	
13	1C3-23188-L0	..O-RING	1	1	1	1	
14	1C3-23188-N0	..O-RING	1	1	1	1	
15	1C3-23188-P0	..O-RING	1	1	1	1	
16	1C3-23188-R0	..O-RING	1	1	1	1	
17	1AE-23147-00	..O-RING	2	2	2	2	
18	1C3-23190-L0	..AIR VALVE COMP.	1	1	1	1	
19	1C3-23142-L0	.SEAT, SPRING UPPER	1	1	1	1	
20	2S2-23141-L1	.SPRING, FRONT FORK	1	1	1	1	
21	1C3-23111-L1	.BOLT, CAP	1	1	1	1	
22	2HH-23158-L0	..GASKET	1	1	1	1	
23	276-23114-00	..GASKET	1	1	1	1	
24	1C3-2314F-M0	.PROTECTOR GUIDE COMP., 1	1	1	1	1	
25	2S2-23103-50	FRONT FORK ASSY (R.H)	1		1	1	



2S27100-F250

FIG. 25 FRONT FORK

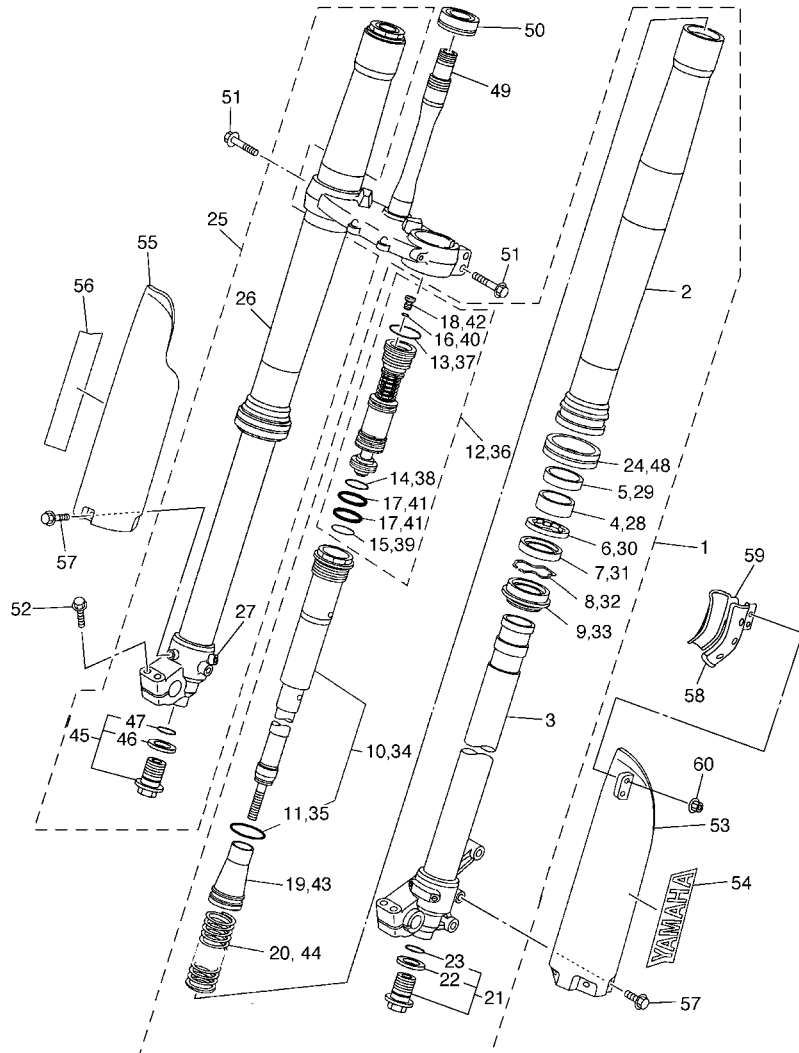

2S27100-F250

REF. NO.	PART NO.	DESCRIPTION	2S27	2S28	2S29	2S2A	REMARKS
26	1C3-23136-M0	.TUBE, OUTER (RIGHT)	1	1	1	1	
27	1C3-23110-M0	.INNER TUBE COMP.1	1	1	1	1	
28	5XE-23171-L0	.PISTON, FRONT FORK	1	1	1	1	
29	5XE-23125-L0	.METAL, SLIDE 1	1	1	1	1	
30	5XE-23146-L0	.WASHER, OIL SEAL	1	1	1	1	
31	1C3-23145-M0	.OIL SEAL	1	1	1	1	
32	5XE-23153-L0	.RING, SNAP	1	1	1	1	
33	5XE-23144-L0	.SEAL, DUST	1	1	1	1	
34	1C3-23170-R0	.CYLINDER COMP., FRONT FORK	1	1	1	1	
35	1C3-23147-L0	..O-RING	1	1	1	1	
36	1C3-2316A-R0	.VALVE COMP.	1	1	1	1	
37	1C3-23188-L0	..O-RING	1	1	1	1	
38	1C3-23188-N0	..O-RING	1	1	1	1	
39	1C3-23188-P0	..O-RING	1	1	1	1	
40	1C3-23188-R0	..O-RING	1	1	1	1	
41	1AE-23147-00	..O-RING	2	2	2	2	
42	1C3-23190-L0	..AIR VALVE COMP.	1	1	1	1	
43	1C3-23142-L0	.SEAT, SPRING UPPER	1	1	1	1	
44	2S2-23141-L1	.SPRING, FRONT FORK	1	1	1	1	
45	1C3-23111-L1	.BOLT, CAP	1	1	1	1	
46	2HH-23158-L0	..GASKET	1	1	1	1	
47	276-23114-00	..GASKET	1	1	1	1	
48	1C3-2314F-M0	.PROTECTOR GUIDE COMP., 1	1	1	1	1	
49	2S2-23340-L0	UNDER BRACKET COMP.	1	1	1	1	
50	93332-00081	BEARING	1	1	1	1	
51	90105-08154	BOLT, FLANGE	4	4	4	4	
52	90105-08134	BOLT, FLANGE	4	4	4	4	

D11

FIG. 26 FUEL TANK

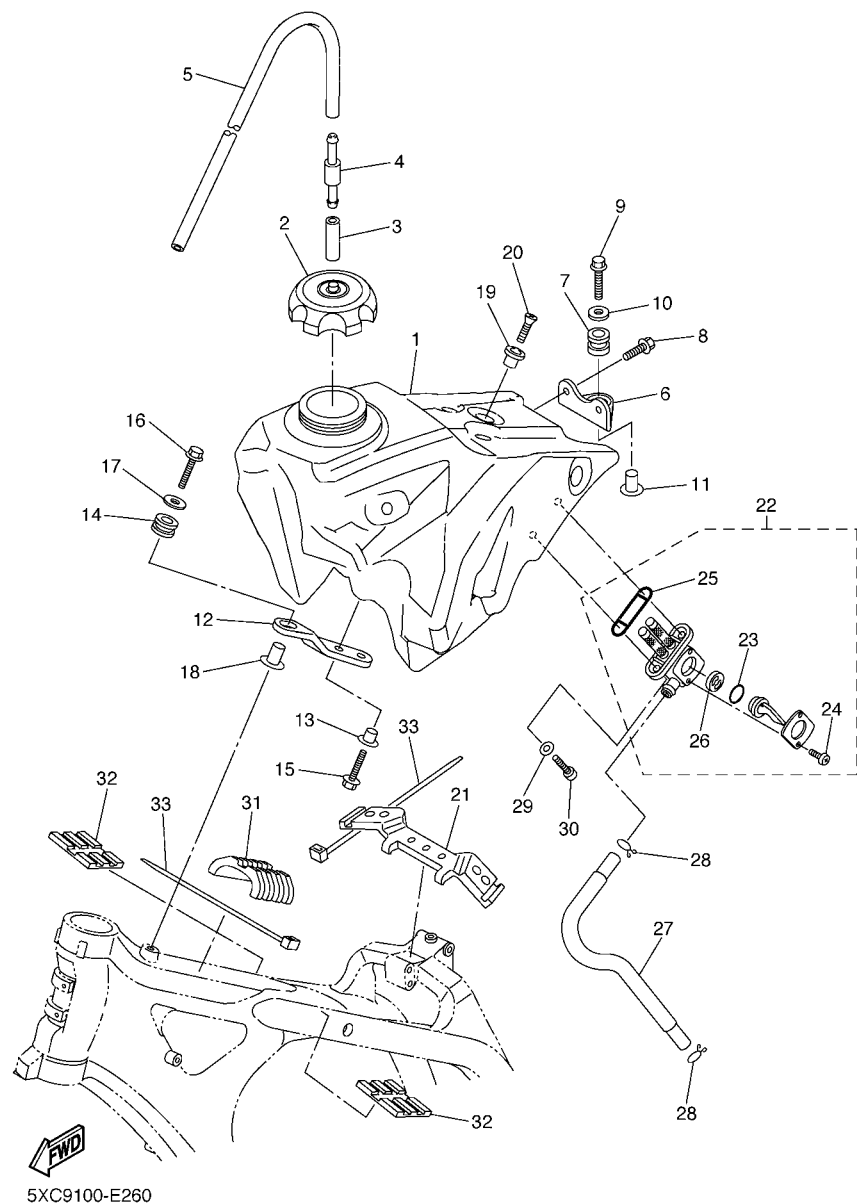

REF. NO.	PART NO.	DESCRIPTION	2S27	2S28	2S29	2S2A	REMARKS
1	2S2-24110-70	FUEL TANK COMP.	1	1	1	1	
2	5NY-24610-00	CAP ASSY	1	1	1	1	
3	90445-09220	HOSE (L30)	1	1	1	1	
4	3XJ-24380-00	PIPE JOINT ASSY	1	1	1	1	
5	90445-09251	HOSE (L350)	1	1	1	1	
6	5XE-24144-00	HOLDER, DAMPER	1	1	1	1	
7	90480-18549	GROMMET	1	1	1	1	
8	90105-06107	BOLT, FLANGE	2	2	2	2	
9	90105-06111	BOLT, FLANGE	1	1	1	1	
10	90201-06570	WASHER, PLATE	1	1	1	1	
11	3JD-24186-00	WASHER, SPECIAL	1	1	1	1	
12	5XC-2419A-90	HOLDER	1	1	1	1	
13	90387-06090	COLLAR	2	2	2	2	
14	5XC-24339-90	GROMMET	1	1	1	1	
15	90105-06107	BOLT, FLANGE	2	2	2	2	
16	90105-06111	BOLT, FLANGE	1	1	1	1	
17	90201-06570	WASHER, PLATE	1	1	1	1	
18	90387-06065	COLLAR	1	1	1	1	
19	4EW-2412F-00	BRACKET, SEAT	1	1	1	1	
20	98702-06025	SCREW, FLAT HEAD	1	1	1	1	
21	5XC-24181-90	DAMPER, LOCATING 1	1	1	1	1	
22	4JT-24500-10	FUEL COCK ASSY 1	1	1	1	1	
23	3AJ-24534-01	.SEAL, COCK	1	1	1	1	
24	98502-03008	.SCREW, PAN HEAD	2	2	2	2	
25	4X8-24512-00	.O-RING	1	1	1	1	
26	3AC-24523-00	.VALVE PACKING	1	1	1	1	
27	2S2-24311-00	PIPE, FUEL 1	1	1	1	1	

FIG. 27 SEAT

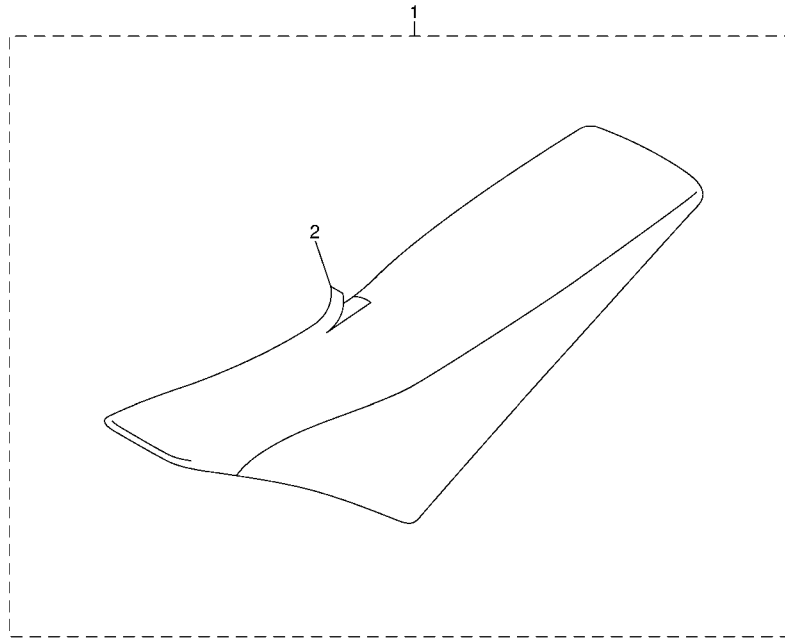

REF. NO.	PART NO.	DESCRIPTION	2S27	2S28	2S29	2S2A	REMARKS
1	2S2-24710-70	SINGLE SEAT ASSY	1		1	1	UR FOR DPBSE
	2S2-24710-80	SINGLE SEAT ASSY	1			1	UR FOR PWS1
2	5XC-2470F-90	.SEAT COVER COMP.	1		1	1	UR FOR DPBSE
	2S2-2470F-80	.SEAT COVER COMP.	1			1	UR FOR PWS1



5XC9100-E270

FIG. 28 FRONT WHEEL

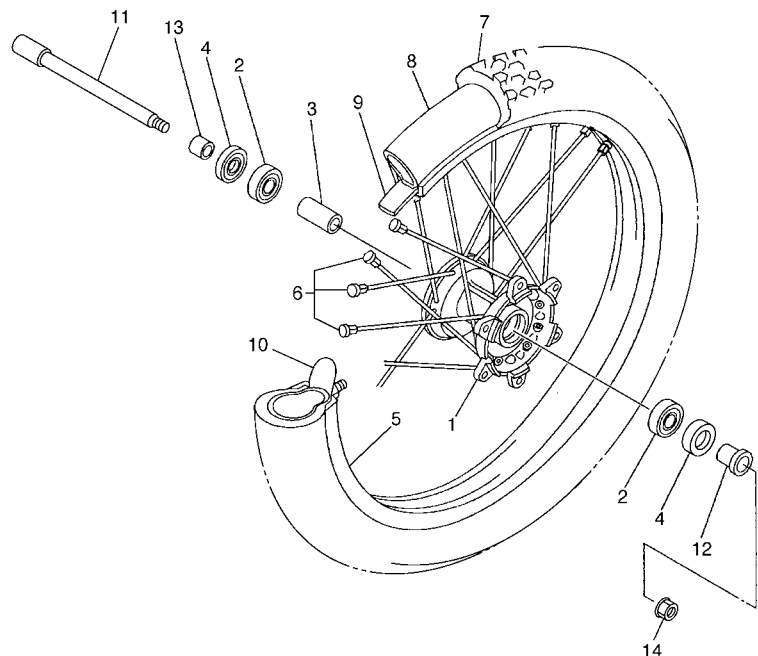

REF. NO.	PART NO.	DESCRIPTION	2S27	2S28	2S29	2S2A	REMARKS
1	5NY-25111-00	HUB, FRONT	1	1	1	1	
2	93306-90409	BEARING	2	2	2	2	
3	5NY-25117-00	SPACER, BEARING	1	1	1	1	
4	93102-26468	OIL SEAL	2	2	2	2	
5	94416-21034	RIM (1.60-21)	1	1	1	1	
6	5NY-25104-00	SPOKE SET, FRONT	1	1	1	1	
7	L.M.	TIRE (80/100-21 51M D739FA)				1	
8	L.M.	TUBE (80/100-21 M/C TR4)				1	
9	94309-21161	BAND, RIM (1.60-21)	1	1		1	DUNLOP FOR FRA
10	5SF-25394-00	SPACER, BEAD	1	1	1	1	
11	1C3-25181-10	AXLE, WHEEL	1	1	1	1	
12	5NY-25183-00	COLLAR, WHEEL	1	1	1	1	
13	5NY-25186-00	COLLAR, WHEEL	1	1	1	1	
14	90179-16011	NUT	1	1	1	1	



5XD5100-D280

FIG. 29 FRONT BRAKE CALIPER

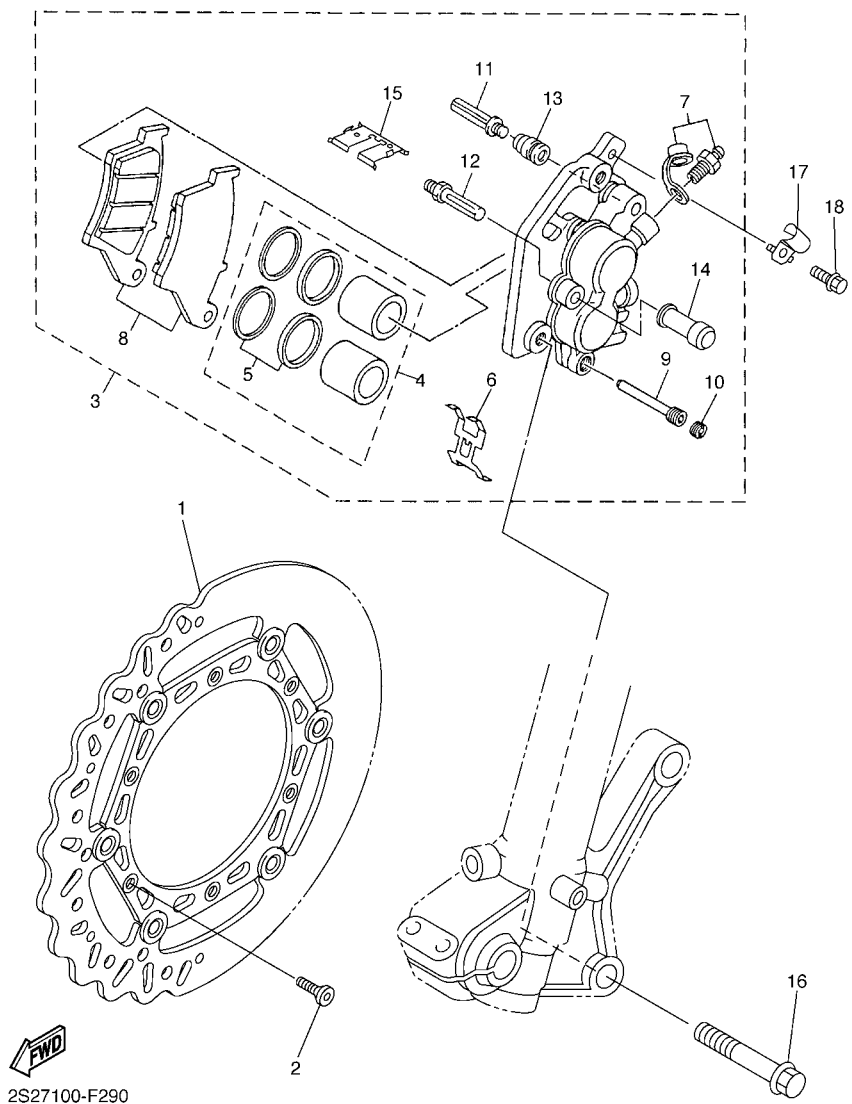

2S27100-F290

REF. NO.	PART NO.	DESCRIPTION	2S27	2S28	2S29	2S2A	REMARKS
1	2S2-2581T-70	DISK BRAKE ASSY	1	1	1	1	
2	90149-06327	SCREW	6	6	6	6	
3	1C3-2580T-00	CALIPER ASSY (LEFT)	1	1	1	1	
4	5UN-W0057-00	.PISTON ASSY, CALIPER	1	1	1	1	
5	3JD-W0047-00	..CALIPER SEAL KIT	1	1	1	1	
6	5DH-25919-00	.SUPPORT, PAD	1	1	1	1	
7	1UY-W0048-50	.BLEED SCREW KIT	1	1	1	1	
8	5MV-W0045-01	.BRAKE PAD KIT	1	1	1	1	
9	5DH-25933-00	.PIN, PAD	1	1	1	1	
10	5DH-25916-00	.PLUG	1	1	1	1	
11	3SP-25926-51	.BOLT	1	1	1	1	
12	3SP-25914-51	.PIN, SLIDE	1	1	1	1	
13	3JD-25917-00	.BOOT, CALIPER	1	1	1	1	
14	1UY-25937-51	.BOOT 2	1	1	1	1	
15	5DH-25849-00	.RETAINER, CALIPER	1	1	1	1	
16	90105-08137	BOLT, FLANGE	2	2	2	2	
17	1C3-25875-50	HOLDER, BRAKE HOSE 1	1	1	1	1	
18	90105-06105	BOLT, FLANGE	1	1	1	1	

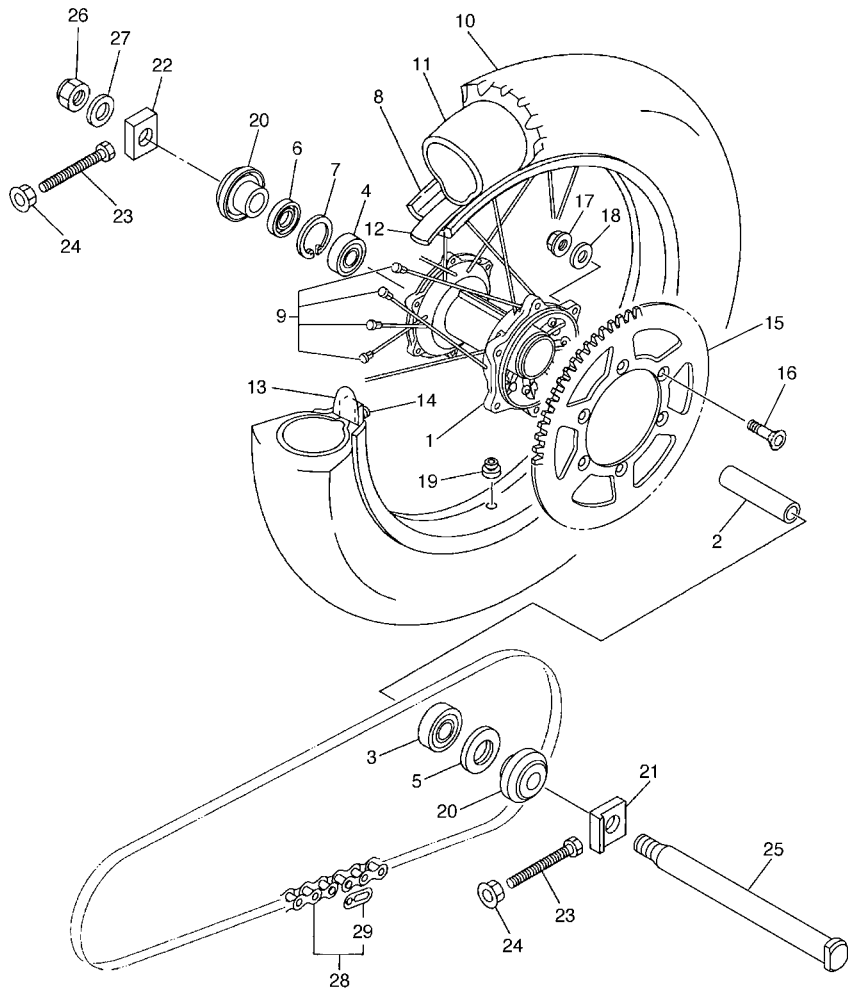

5XC9100-E300

FIG. 30 REAR WHEEL

REF. NO.	PART NO.	DESCRIPTION	2S27	2S28	2S29	2S2A	REMARKS
1	5ET-25311-00	HUB, REAR	1	1	1	1	
2	5ET-25317-00	SPACER, BEARING	1	1	1	1	
3	93306-27212	BEARING	1	1	1	1	
4	93306-07202	BEARING	1	1	1	1	
5	93106-30001	OIL SEAL	1	1	1	1	
6	93106-30045	OIL SEAL	1	1	1	1	
7	99009-45500	CIRCLIP	1	1	1	1	
8	94421-19005	RIM (2.15-19)	1	1	1	1	
9	5HD-25304-00	SPOKE SET, REAR	1	1	1	1	
10	L.M.	TIRE (110/90-19 62M D756)				1	
11	L.M.	TUBE (110/90-19 M/C TR4)				1	
12	94311-19155	BAND, RIM (2.15-19)	1	1		1	
13	3JE-25394-00	SPACER, BEAD	1	1	1	1	
14	4XM-25364-00	DAMPER	1	1	1	1	
15	1C3-25449-00	SPROCKET, DRIVEN (49T)	1	1	1	1	STD
	1C3-25447-00	SPROCKET, DRIVEN (47T)	1	1	1	1	AP
	1C3-25448-00	SPROCKET, DRIVEN (48T)	1	1	1	1	AP
	1C3-25450-00	SPROCKET, DRIVEN (50T)	1	1	1	1	AP
	1C3-25451-00	SPROCKET, DRIVEN (51T)	1	1	1	1	AP
	1C3-25452-00	SPROCKET, DRIVEN (52T)	1	1	1	1	AP

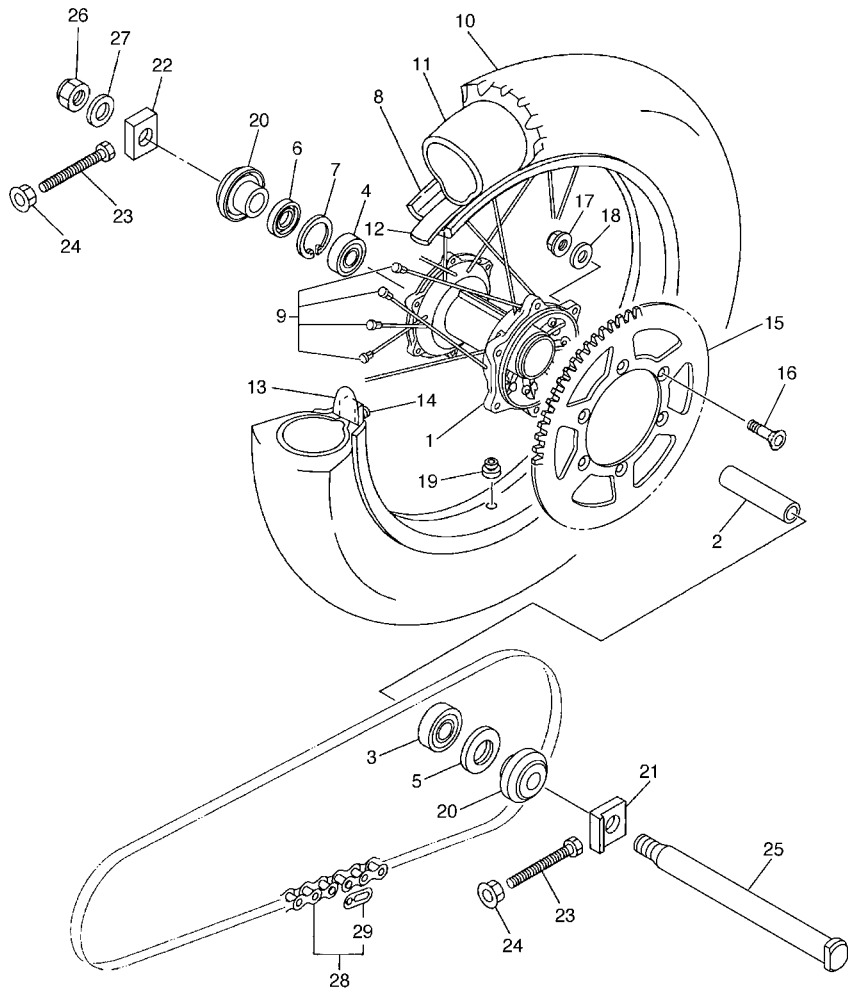

FIG. 30 REAR WHEEL

REF. NO.	PART NO.	DESCRIPTION					REMARKS
			2S27	2S28	2S29	2S2A	
16	90109-08078	BOLT	6	6	6	6	
17	90185-08008	NUT, SELF-LOCKING	6	6	6	6	
18	90201-08048	WASHER, PLATE	6	6	6	6	
19	90480-08608	GROMMET	1	1	1	1	
20	5TJ-2530S-80	COLLAR ASSY	2	2	2	2	
21	1C3-25388-50	PULLER, CHAIN 1	1	1	1	1	
22	1C3-25389-00	PULLER, CHAIN 2	1	1	1	1	
23	90101-08006	BOLT	2	2	2	2	
24	90179-08674	NUT	2	2	2	2	
25	1C3-25381-90	AXLE, WHEEL	1	1	1	1	
26	90185-20002	NUT, SELF-LOCKING	1	1	1	1	
27	90201-20020	WASHER, PLATE	1	1	1	1	
28	9Y581-92113	CHAIN (DID 520D 114L)	1	1	1	1	
29	94681-68001	.JOINT,CHAIN (DID 520DM-RJ)	1	1	1	1	



5XC9100-E300

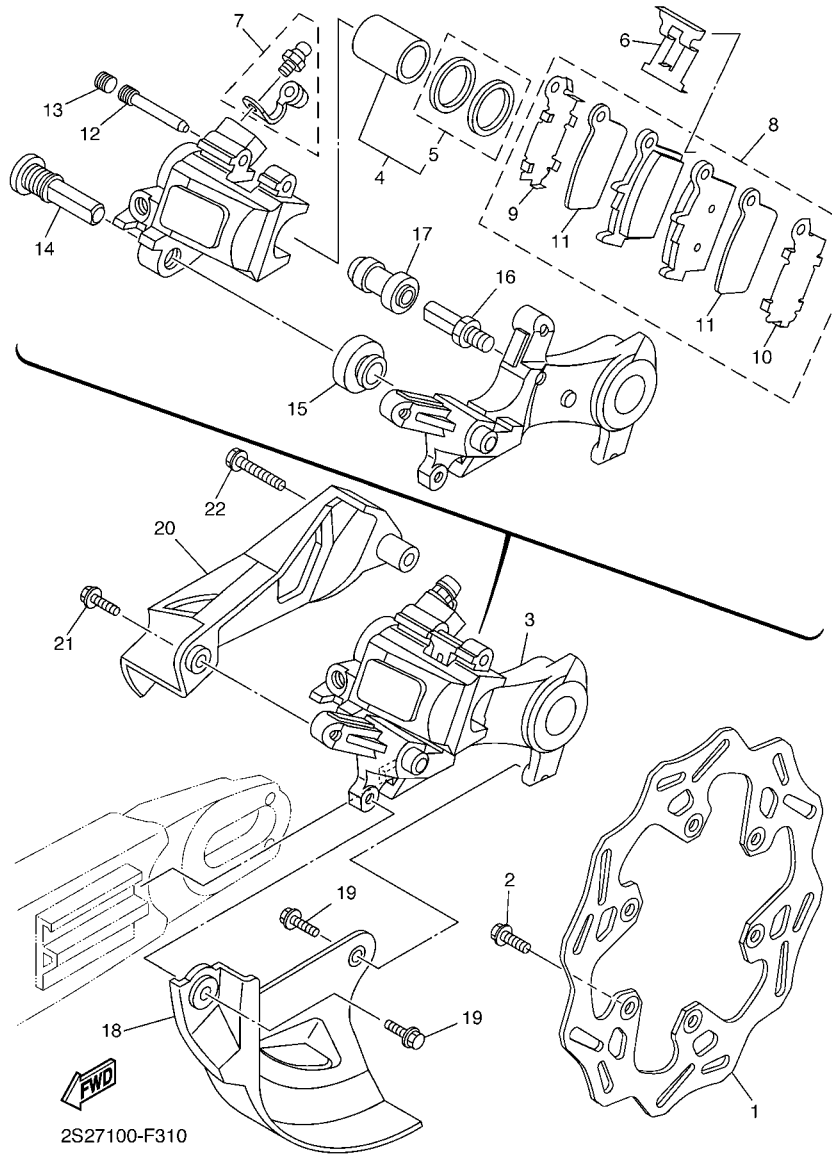
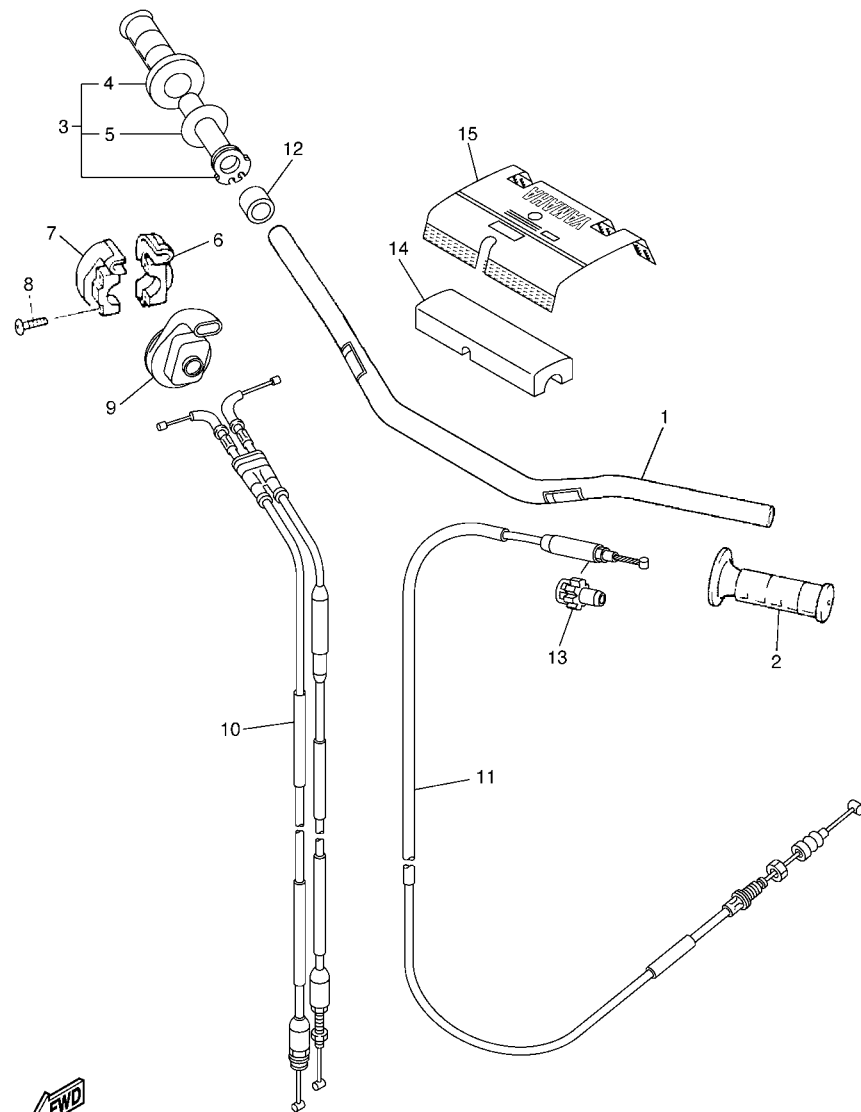

FIG. 31 REAR BRAKE CALIPER

REF. NO.	PART NO.	DESCRIPTION	2S27	2S28	2S29	2S2A	REMARKS
1	2S2-2582W-70	DISK, REAR BRAKE 2	1	1	1	1	
2	90105-06108	BOLT, FLANGE	6	6	6	6	
3	1C3-2580W-50	CALIPER ASSY, REAR 2	1	1	1	1	
4	5UN-W0057-50	.PISTON ASSY, CALIPER	1	1	1	1	
5	5UN-W0047-50	..CALIPER SEAL KIT	1	1	1	1	
6	5DH-25919-50	..SUPPORT, PAD	1	1	1	1	
7	1UY-W0048-50	.BLEED SCREW KIT	1	1	1	1	
8	1C3-W0046-50	.BRAKE PAD KIT 2	1	1	1	1	
9	5UN-25828-60	..SHIM, CALIPER	1	1	1	1	
10	5UN-25827-60	..SHIM, CALIPER	1	1	1	1	
11	5UN-22898-60	..INSULATOR, HEAT	2	2	2	2	
12	8CR-25924-00	.PIN, PAD	1	1	1	1	
13	5DH-25916-00	.PLUG	1	1	1	1	
14	5DH-25914-50	.PIN, SLIDE	1	1	1	1	
15	3JD-25917-00	.BOOT, CALIPER	1	1	1	1	
16	5UN-25914-00	.PIN, SLIDE	1	1	1	1	
17	1UY-25937-51	.BOOT 2	1	1	1	1	
18	1C3-25718-50	PROTECTOR, DISK BRAKE	1	1	1	1	
19	90105-06110	BOLT, FLANGE	2	2	2	2	
20	1C3-27491-50	PROTECTOR	1	1	1	1	
21	90105-06107	BOLT, FLANGE	1	1	1	1	
22	90105-06111	BOLT, FLANGE	1	1	1	1	



5XC9100-E320

FIG. 32 STEERING HANDLE & CABLE

REF. NO.	PART NO.	DESCRIPTION	2S27	2S28	2S29	2S2A	REMARKS
1	1C3-26111-90	HANDLEBAR	1	1	1	1	
2	4GY-26241-00	GRIP	1	1	1	1	
3	5TJ-26240-C0	GRIP ASSY	1	1	1	1	
4	4GY-26242-00	.GRIP (RIGHT)	1	1	1	1	
5	3Y1-26249-00	.RING, LEAF	1	1	1	1	
6	5BE-26281-00	CAP, GRIP UPPER	1	1	1	1	
7	5BE-26282-00	CAP, GRIP LOWER	1	1	1	1	
8	98502-05020	SCREW, PAN HEAD	2	2	2	2	
9	5SF-26287-10	COVER, CAP GRIP	1	1	1	1	
10	2S2-26302-00	THROTTLE CABLE ASSY	1	1	1	1	
11	2S2-26335-70	CABLE, CLUTCH	1	1	1	1	
12	90387-225N2	COLLAR	1	1	1	1	
13	1C3-26342-50	BOOT, CABLE	1	1	1	1	
14	5XC-26124-90	PROTECTOR, HANDLEBAR	1	1	1	1	
15	5XC-26143-90	COVER, HANDLEBAR UPPER 1	1	1	1	1	UR FOR DPBSE
	2S2-26143-70	COVER, HANDLEBAR UPPER 1	1	1		1	UR FOR PWS1

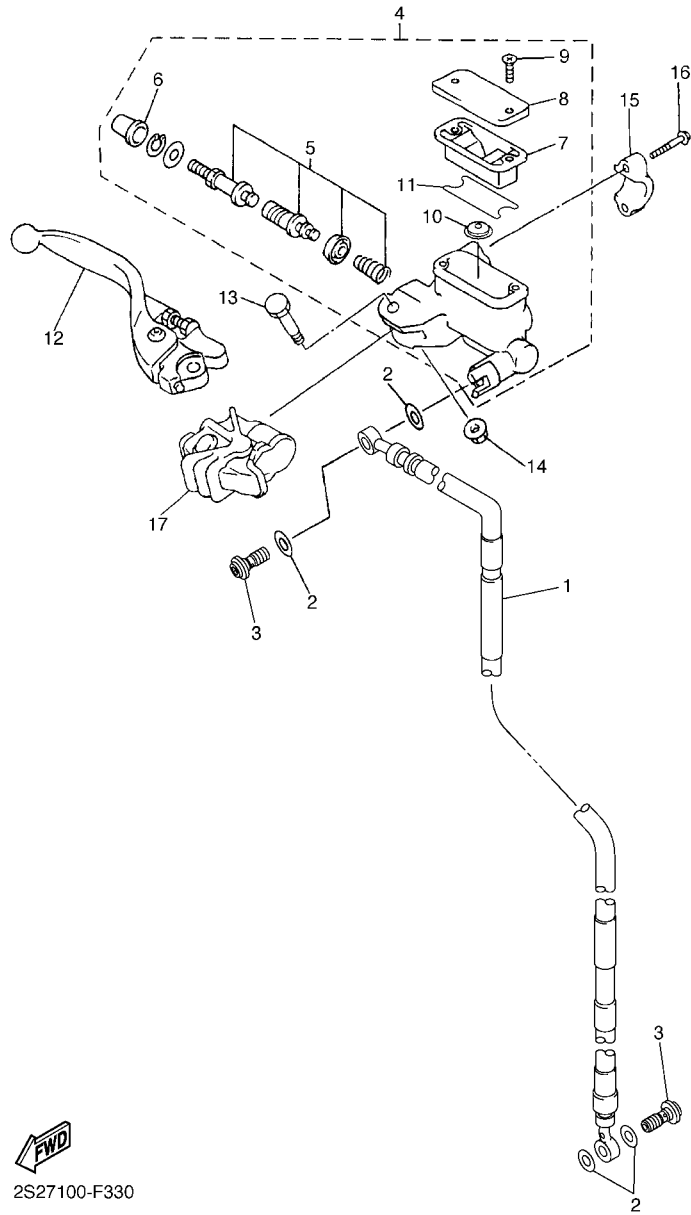

2S27100-F330

FIG. 33 FRONT MASTER CYLINDER

REF. NO.	PART NO.	DESCRIPTION	2S27	2S28	2S29	2S2A	REMARKS
1	1C3-25872-90	HOSE, BRAKE 1	1	1	1	1	
2	90430-10005	GASKET	4	4	4	4	
3	90401-10172	BOLT, UNION	2	2	2	2	
4	5XE-W2587-10	MASTER CYLINDER SUB ASSY	1	1	1	1	
5	5NY-W0041-00	.CYLINDER KIT, MASTER	1	1	1	1	
6	5NY-25868-00	.BOOT, MASTER CYLINDER	1	1	1	1	
7	5XE-25854-00	.DIAPHRAGM, RESERVOIR	1	1	1	1	
8	5MV-25852-01	.CAP, RESERVOIR	1	1	1	1	
9	98706-04012	.SCREW, FLAT HEAD	2	2	2	2	
10	5CG-25715-00	.SEPARATOR ASSY	1	1	1	1	
11	5XE-25853-00	.FLOAT, RESERVOIR	1	1	1	1	
12	1C3-83922-50	LEVER 2	1	1	1	1	
13	5MV-2589F-00	BOLT, LEVER	1	1	1	1	
14	95701-06500	NUT, FLANGE	1	1	1	1	
15	5MV-25867-00	BRACKET, MASTER CYLINDER	1	1	1	1	
16	5MV-25833-00	BOLT, FITTING	2	2	2	2	
17	5NY-26372-00	COVER, HANDLE LEVER 1	1	1	1	1	

FIG. 34 STAND & FOOTREST

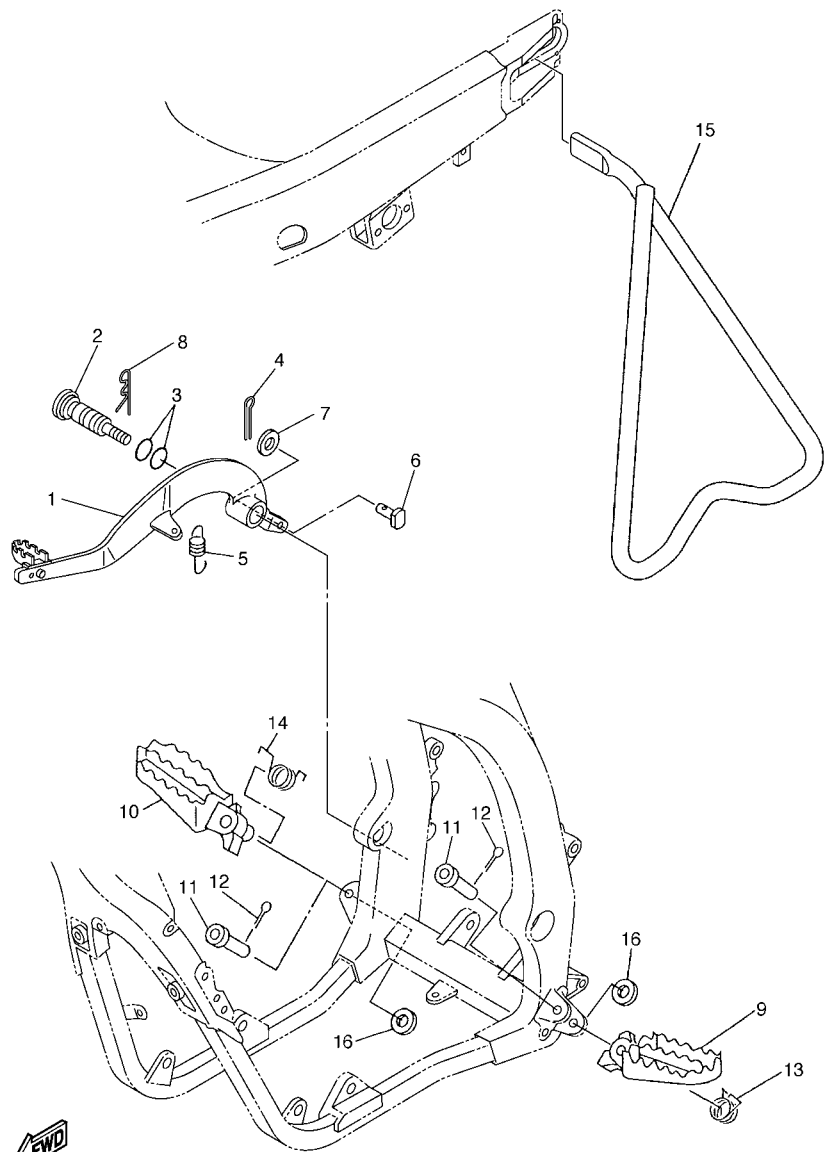

2S21100-E340

REF. NO.	PART NO.	DESCRIPTION	2S27	2S28	2S29	2S2A	REMARKS
1	2S2-27200-10	PEDAL, BRAKE	1	1	1	1	
2	1C3-27217-10	BOLT	1	1	1	1	
3	93210-11073	O-RING	2	2	2	2	
4	91402-20012	PIN, COTTER	1	1	1	1	
5	90506-16007	SPRING, TENSION	1	1	1	1	
6	90240-08120	PIN, CLEVIS	1	1	1	1	
7	90201-08044	WASHER, PLATE	1	1	1	1	
8	90468-16001	CLIP	1	1	1	1	
9	5XE-27411-01	FOOTREST 1	1	1	1	1	
10	5XE-27421-01	FOOTREST 2	1	1	1	1	
11	90240-10004	PIN, CLEVIS	2	2	2	2	
12	91402-25015	PIN, COTTER	2	2	2	2	
13	90508-28015	SPRING, TORSION	1	1	1	1	
14	90508-28018	SPRING, TORSION	1	1	1	1	
15	1C3-27311-00	STAND, SIDE	1	1	1	1	
16	90201-10032	WASHER, PLATE	2	2	2	2	

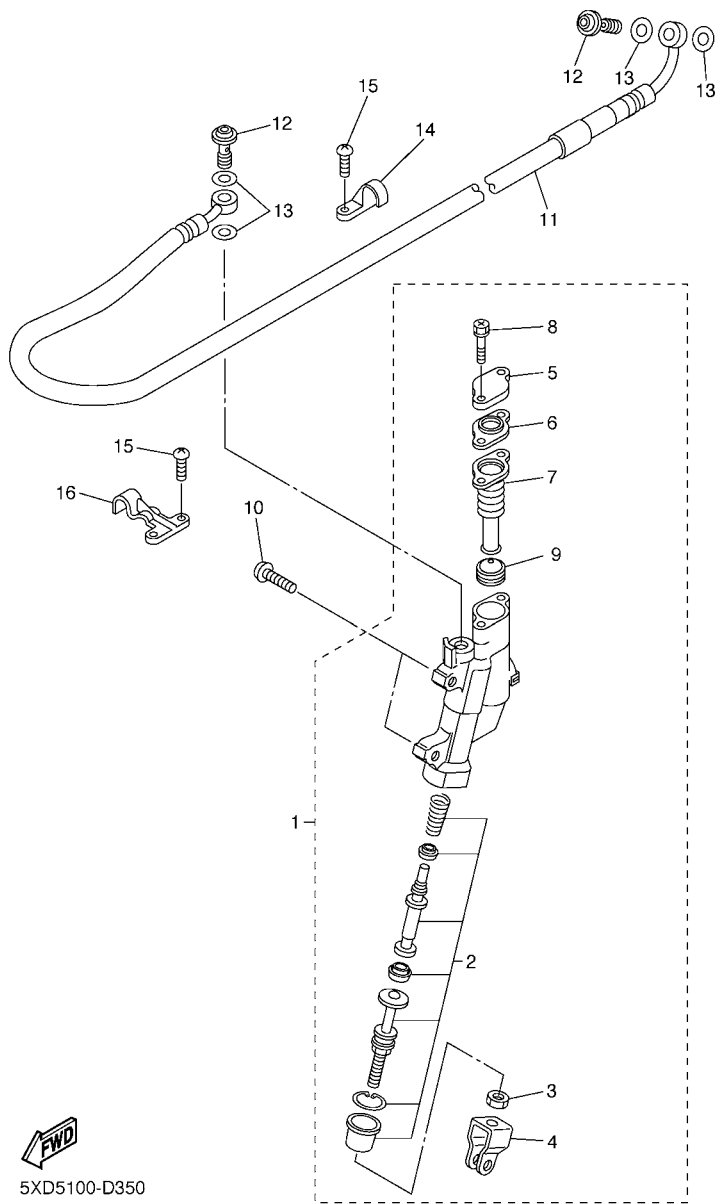

FWD
5XD5100-D350

FIG. 35 REAR MASTER CYLINDER

REF. NO.	PART NO.	DESCRIPTION	2S27	2S28	2S29	2S2A	REMARKS
1	1C3-2583V-00	RR. MASTER CYLINDER ASSY.	1	1	1	1	
2	5UN-W0042-50	.CYLINDER KIT, MASTER	1	1	1	1	
3	5UN-27218-00	.NUT	1	1	1	1	
4	5UN-27222-00	.JOINT	1	1	1	1	
5	5UN-25852-50	.CAP, RESERVOIR	1	1	1	1	
6	5UN-2585B-00	.PLATE, DIAPHRAGM	1	1	1	1	
7	5UN-25854-00	.DIAPHRAGM, RESERVOIR	1	1	1	1	
8	5UN-27217-00	.BOLT	2	2	2	2	
9	5CG-25715-00	.SEPARATOR ASSY	1	1	1	1	
10	90111-06059	BOLT,HEX. SOCKET BUTTON	2	2	2	2	
11	1C3-25873-00	HOSE, BRAKE 2	1	1	1	1	
12	90401-10172	BOLT, UNION	2	2	2	2	
13	90430-10005	GASKET	4	4	4	4	
14	1C3-25886-50	HOLDER, BRAKE HOSE	1	1	1	1	
15	98502-05010	SCREW, PAN HEAD	4	4	4	4	
16	1C3-25876-50	HOLDER, BRAKE HOSE 2	1	1	1	1	

FIG. 36 GENERATOR

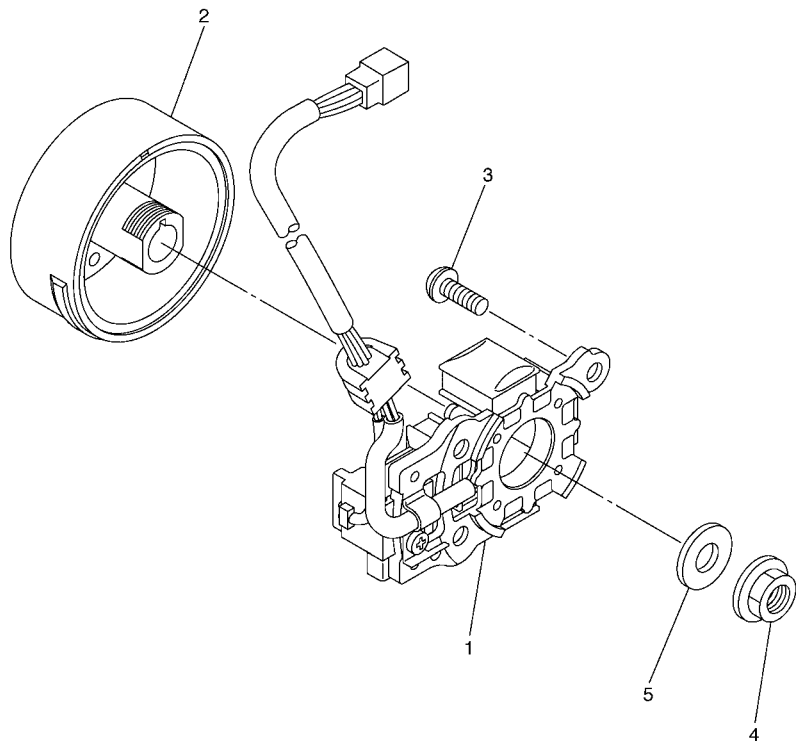

REF. NO.	PART NO.	DESCRIPTION	2S27	2S28	2S29	2S2A	REMARKS
1	2S2-85560-00	BASE ASSY	1	1	1	1	
2	2S2-85550-00	ROTOR ASSY	1	1	1	1	
3	90149-06081	SCREW	3	3	3	3	
4	90179-12657	NUT	1	1	1	1	
5	90201-127E1	WASHER, PLATE	1	1	1	1	

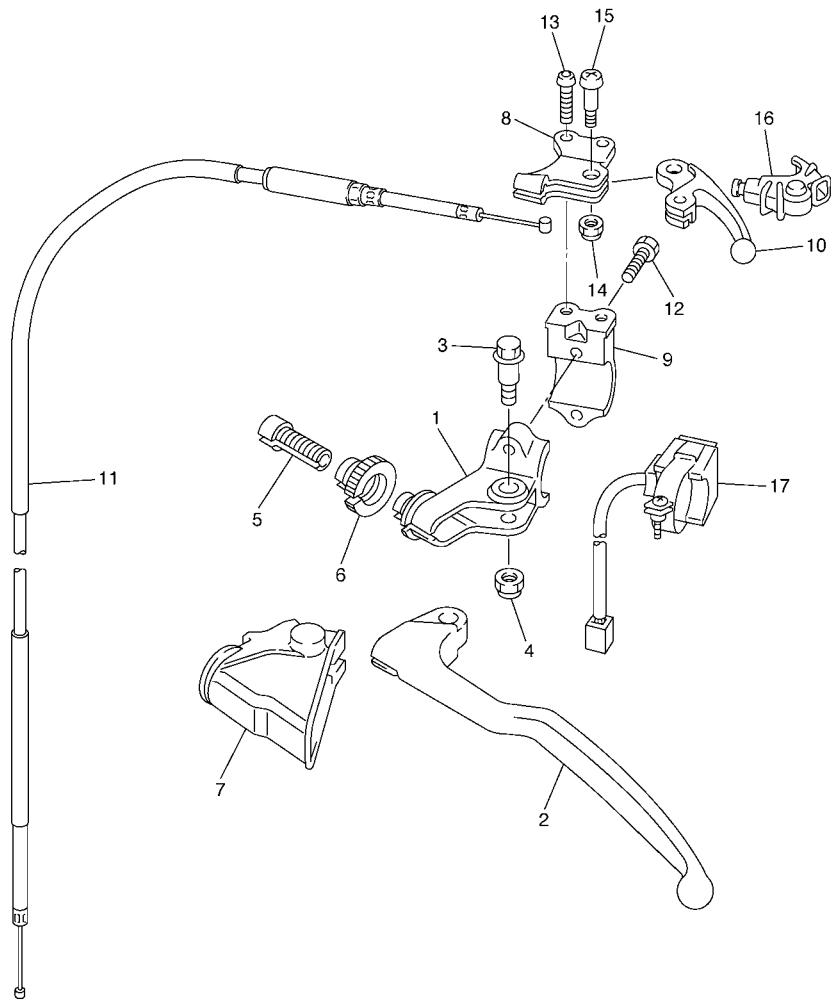

2S21100-E360



5XC9100-E370

FIG. 37 HANDLE SWITCH & LEVER

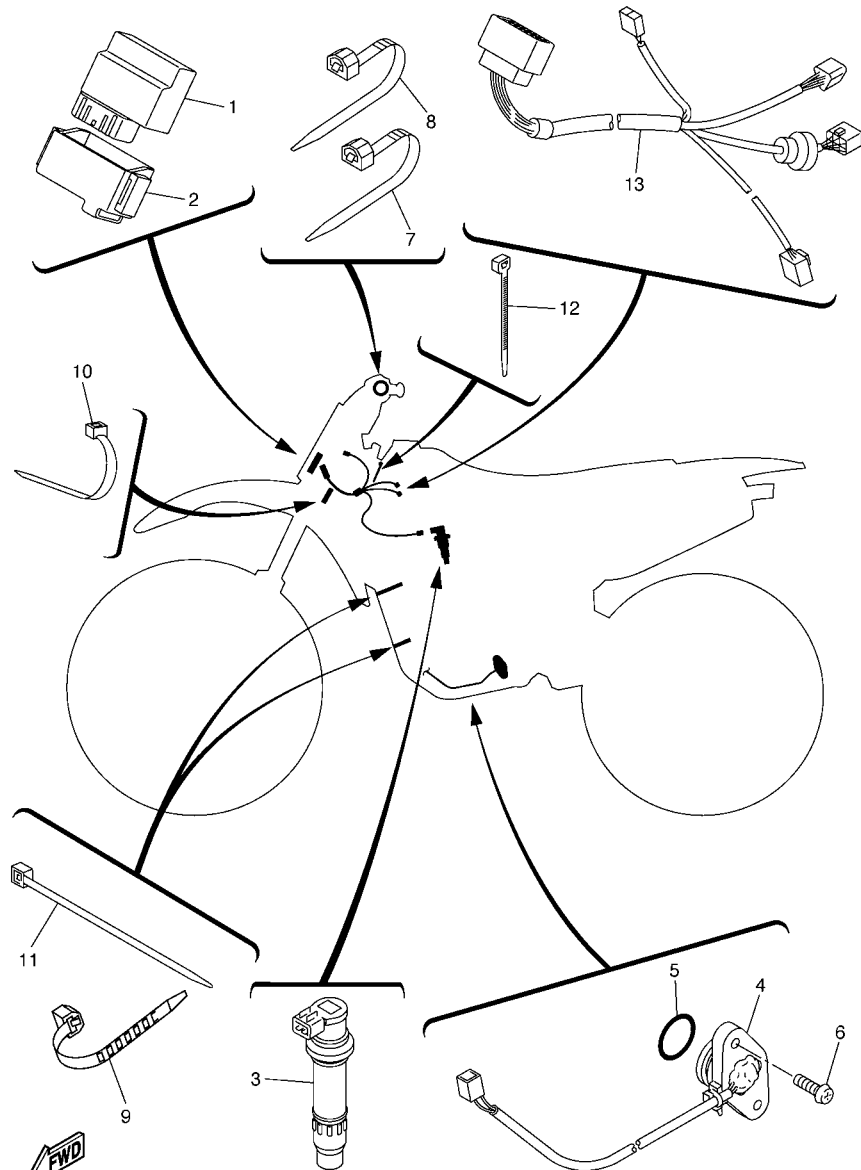
REF. NO.	PART NO.	DESCRIPTION	2S27	2S28	2S29	2S2A	REMARKS
1	5XE-82911-00	HOLDER, LEVER 1	1	1	1	1	
2	5MV-83912-00	LEVER 1	1	1	1	1	
3	90109-06034	BOLT	1	1	1	1	
4	5LP-84126-10	NUT, LENS FITTING	1	1	1	1	
5	5HD-26337-00	BOLT, ADJUSTING	1	1	1	1	
6	5HD-83951-00	BOLT, CABLE ADJUSTING	1	1	1	1	
7	5HD-26372-00	COVER, HANDLE LEVER 1	1	1	1	1	
8	5XD-82946-00	HOLDER, STARTER LEVER	1	1	1	1	
9	5XD-82913-00	HOLDER, LEVER LOWER 1	1	1	1	1	
10	5TA-83941-00	LEVER, STARTER	1	1	1	1	
11	2S2-26334-00	CABLE, STARTER 2	1	1	1	1	
12	97002-05016	BOLT	2	2	2	2	
13	92012-05012	BOLT, BUTTON HEAD	2	2	2	2	
14	95602-05100	NUT, U	1	1	1	1	
15	90149-05162	SCREW	1	1	1	1	
16	5TA-26339-00	BOOT	1	1	1	1	
17	1C3-83976-00	SWITCH, HANDLE 1	1	1	1	1	



2S21100-E380

FIG. 38 ELECTRICAL 1

REF. NO.	PART NO.	DESCRIPTION	2S27	2S28	2S29	2S2A	REMARKS
1	2S2-85540-70	C.D.I. UNIT ASSY	1			1	
2	1C3-85546-00	BAND	1	1	1	1	
3	5TA-82310-10	IGNITION COIL ASSY	1	1	1	1	
4	2S2-82540-00	NEUTRAL SWITCH ASSY	1	1	1	1	
5	93210-21276	O-RING	1	1	1	1	
6	90154-05022	SCREW, BINDING	2	2	2	2	
7	90464-13077	CLAMP	1	1	1	1	
8	90464-13073	CLAMP	1	1	1	1	
9	90464-15195	CLAMP	2	2	2	2	
10	5Y9-12491-00	CLAMP 1	1	1	1	1	
11	90465-13275	CLAMP	4	4	4	4	
12	90465-13275	CLAMP	1	1	1	1	
13	2S2-82509-00	WIRE, SUB LEAD	1	1	1	1	

FIG. 39 ALTERNATE FOR CHASSIS

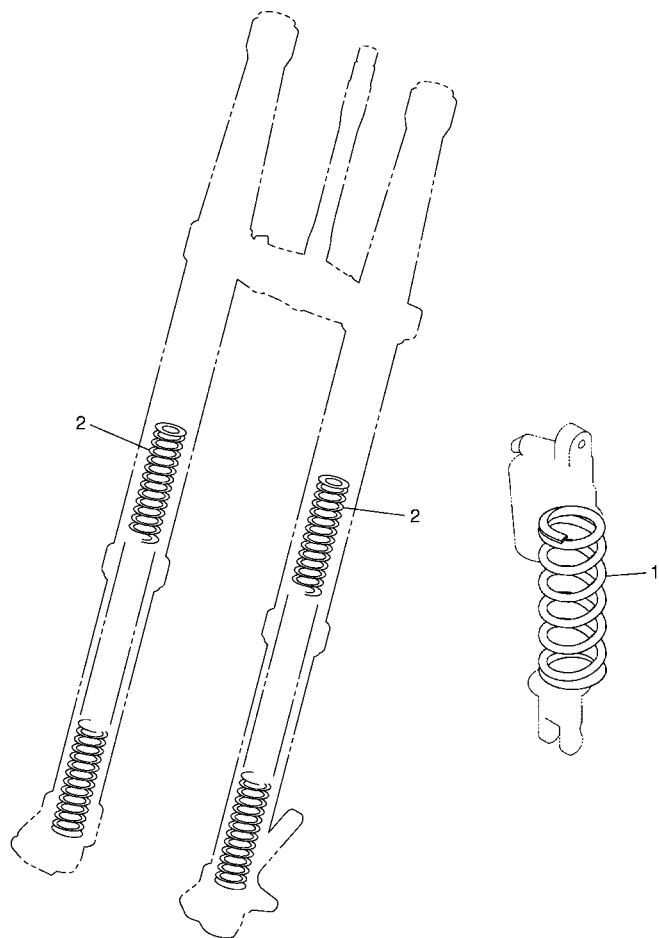

REF. NO.	PART NO.	DESCRIPTION	2S27	2S28	2S29	2S2A	REMARKS
1	5UN-22212-00	SPRING (K=42N/MM)	1	1	1	1	AP
	1C3-22212-00	SPRING (K=44N/MM)	1	1	1	1	AP
	1C3-22212-10	SPRING (K=46N/MM)	1	1	1	1	AP
	1C3-22212-20	SPRING (K=48N/MM)	1	1	1	1	AP
	1C3-22212-30	SPRING (K=50N/MM)	1	1	1	1	AP
	1C3-22212-40	SPRING (K=52N/MM)	1	1	1	1	AP
	1C3-22212-50	SPRING (K=54N/MM)	1	1	1	1	AP
	1C3-22212-60	SPRING (K=55.8N/MM)	1	1	1	1	AP
	5UN-22212-A0	SPRING (K=APPROX.44N/MM)	1	1	1	1	AP
	5UN-22212-B0	SPRING (K=APPROX.46N/MM)	1	1	1	1	AP
	5UN-22212-C0	SPRING (K=APPROX.48N/MM)	1	1	1	1	AP
	5UN-22212-D0	SPRING (K=APPROX.50N/MM)	1	1	1	1	AP
	5UN-22212-E0	SPRING (K=APPROX.52N/MM)	1	1	1	1	AP
	5UN-22212-F0	SPRING (K=APPROX.54N/MM)	1	1	1	1	AP
	5UN-22212-G0	SPRING (K=APPROX.56N/MM)	1	1	1	1	AP
2	1C3-23141-A1	SPRING, FRONT FORK(K=3.9N/MM)	2	2	2	2	AP
	1C3-23141-B1	SPRING, FRONT FORK(K=4.0N/MM)	2	2	2	2	AP
	1C3-23141-C1	SPRING, FRONT FORK(K=4.1N/MM)	2	2	2	2	AP
	1C3-23141-D1	SPRING, FRONT FORK(K=4.2N/MM)	2	2	2	2	AP
	1C3-23141-E1	SPRING, FRONT FORK(K=4.3N/MM)	2	2	2	2	AP
	1C3-23141-F1	SPRING, FRONT FORK(K=4.4N/MM)	2	2	2	2	AP
	1C3-23141-G1	SPRING, FRONT FORK(K=4.5N/MM)	2	2	2	2	AP
	1C3-23141-J1	SPRING, FRONT FORK(K=4.7N/MM)	2	2	2	2	AP



5XC9100-E390

NUMERICAL INDEX

PART NO.	GRID NO.	PART NO.	GRID NO.	PART NO.	GRID NO.	PART NO.	GRID NO.	PART NO.	GRID NO.	PART NO.	GRID NO.
2S2-11102-00	B - 2	3LD-12168-U1	B - 5	5NL-14105-00	B - 15	5JG-14565-00	C - 2	4MX-14943-87	B - 14	2S2-15451-00	C - 6
5VY-1111G-00	B - 2	3LD-12168-W1	B - 5	4MX-14115-00	C - 2	5JG-14591-00	C - 2	4MX-14943-88	B - 14	5TA-15453-00	C - 6
5TA-11133-10	B - 2	3LD-12168-Y1	B - 5	3TJ-14137-40	B - 12	688-14592-00	B - 13	4MX-14943-89	B - 14	2S2-15462-10	C - 6
5TA-11134-10	B - 2	3LD-12169-11	B - 5			2S2-14611-20	C - 3	4MX-14943-90	B - 14	2S2-15601-00	C - 8
2S2-11166-00	B - 2	3LD-12169-31	B - 6	5BE-14146-00	C - 2	3VD-14613-01	C - 3	4MX-14943-91	B - 14	2S2-15620-01	C - 8
371-11167-01	B - 2	3LD-12169-50	B - 6	5PA-14146-00	C - 2	5TA-14628-00	C - 3	4MX-14943-92	B - 14	5XD-15621-00	C - 8
2S2-11181-00	B - 2	3LD-12169-70	B - 6	5TA-14155-00	B - 15	2S2-1469A-00	C - 3	5XD-14947-00	B - 14	5TA-15651-00	C - 8
2S2-11190-00	B - 2	3LD-12169-90	B - 6	633-14159-00	B - 15	2S2-1469A-10	C - 3	4MX-14948-02	B - 14	5GR-15664-00	C - 8
2S2-11193-00	B - 2	3LD-12169-E0	B - 6	3TJ-14159-40	B - 13			4MX-14948-03	B - 14	5SG-15668-00	C - 8
2S2-11311-10	B - 2	3LD-12169-G0	B - 6	5XC-14171-00	B - 15	2S2-1469E-00	C - 3	4MX-14948-04	B - 14	2S2-15671-00	C - 8
2S2-11351-00	B - 3	3LD-12169-J0	B - 6	3TJ-14191-40	B - 15			4MX-14948-05	B - 14	214-15686-00	C - 8
2S2-11400-00	B - 4	3LD-12169-L0	B - 6	5UL-14196-00	C - 2	2S2-1469F-00	C - 3	4MX-14948-06	B - 14	2S2-16111-10	C - 9
2S2-11412-00	B - 4	3LD-12169-N0	B - 6	5TA-14197-00	C - 2			4MX-14948-07	B - 14	5XD-16150-50	C - 9
2S2-11422-00	B - 4	3LD-12169-T0	B - 6	5NX-14216-00	C - 2	2S2-14714-00	E - 15	4MX-14948-08	B - 14	5XD-16154-00	C - 9
2S2-11454-10	B - 4	5TA-12170-20	B - 7	5TA-14227-00	B - 12	5VY-14714-00	C - 3	4JT-1494F-05	B - 15	5TA-16321-00	C - 9
2S2-11455-00	B - 4	5TA-12180-20	B - 7	5TA-14239-00	B - 12	5BE-14747-00	E - 15	4JT-1494F-07	B - 15	4X7-16325-00	C - 9
2S2-11464-10	B - 4	5TA-12210-10	B - 7	5TA-14261-00	C - 2			4JT-1494F-09	B - 14	2S2-16351-00	C - 9
2S2-11531-00	B - 4	4FM-12213-00	B - 7	5JG-14264-00	B - 14	2S2-14750-30	C - 3	4JT-1494F-11	B - 15	5JG-16356-00	C - 9
2S2-11536-00	B - 4	5BE-12241-00	B - 2	3TJ-14267-40	B - 13	2S2-14750-40	C - 3	4JT-1494F-13	B - 15	2S2-16357-00	C - 9
5JG-11603-00	B - 4	2S2-12251-00	B - 7	5JG-14275-00	B - 14	2S2-14750-50	E - 15	3TJ-1494F-14	B - 14	5TA-16371-10	C - 9
2S2-11631-10	B - 4	5TA-12252-00	B - 7	5TA-14293-00	B - 12	4BD-14766-00	C - 3	3TJ-1494F-15	B - 14	2S2-16380-10	C - 9
5TA-11633-00	B - 4	2S2-1240A-70	B - 9	3TJ-14293-40	B - 15	2S2-14788-00	C - 3	3TJ-1494F-16	B - 14	2S2-17121-00	C - 10
2S2-11651-00	B - 4	5BE-12422-20	B - 8	5XD-14325-00	C - 2	5TA-14916-L1	B - 13	3TJ-1494F-17	B - 14	2S2-17131-00	C - 10
5TG-11681-00	B - 4	5BE-12439-00	B - 8	5TA-14335-00	B - 15	5TA-14916-LN	B - 13	3TJ-1494F-18	B - 14	2S2-17141-00	C - 10
5TA-12111-00	B - 5	5DJ-12451-00	B - 8	5JG-14346-00	C - 2	5TA-14916-LP	B - 13	5JG-14951-00	B - 13	2S2-17151-00	C - 10
5TA-12112-00	B - 5	5GR-12458-00	B - 8	5TA-14371-00	B - 15	5TA-14916-LR	B - 13	5JG-14959-00	B - 13	2S2-17211-00	C - 10
5TA-12113-00	B - 5	2S2-12461-70	B - 9	2S2-14374-00	B - 15	5TA-14916-LS	B - 13	5JG-14984-00	B - 15	2S2-17221-00	C - 10
5TA-12114-00	B - 5	22W-12462-00	B - 9	5JG-14379-00	B - 15	5TA-14916-LT	B - 13	4SR-14985-00	B - 15	2S2-17231-00	C - 10
4GY-12117-00	B - 5	2S2-12464-70	B - 9	2S2-14388-00	B - 13	5TA-14916-LU	B - 13	5TA-14987-00	B - 12	2S2-17241-00	C - 10
5BE-12117-00	B - 5	2S2-12481-00	B - 9	4MX-14392-00	B - 15	5TA-14916-P1	B - 13	5TJ-14987-00	C - 2	2S2-17251-00	C - 10
1AA-12118-00	B - 5	1C3-12482-00	B - 9	2S2-14401-70	B - 12	5TA-14916-PN	B - 13	5TA-14991-00	B - 15	2S2-17402-00	C - 10
1WG-12118-00	B - 5	2S2-12482-00	B - 9	5XC-14417-90	B - 12	5TA-14916-PP	B - 13	4FN-14997-00	B - 13	2S2-17411-00	C - 10
33M-12119-00	B - 5	5Y9-12491-00	E - 13	5NY-14442-00	B - 12	5TA-14916-PR	B - 13	5TA-14997-00	B - 15	2S2-17466-00	C - 4
4SV-12119-00	B - 5	5BE-12564-00	B - 8	4XM-14451-00	B - 12	5TA-14916-PS	B - 13	2S2-15100-00	C - 4	2S2-17471-00	C - 11
5TA-12121-00	B - 5	2S2-12576-00	B - 9	2S2-14453-10	B - 12	5TA-14916-PT	B - 13	2S2-15155-00	C - 4	2S2-18101-00	C - 13
3GM-12126-00	B - 5	2S2-12578-00	B - 9	5NY-14455-20	B - 12	5TA-14916-PU	B - 13	3Y1-15363-00	C - 6	2S2-18110-00	C - 13
3FV-12153-10	B - 6	2S2-12579-00	B - 9	5BE-14458-00	B - 12	5XC-14922-00	C - 2	2S2-1536A-00	C - 4	5MW-18122-01	C - 13
3LD-12168-00	B - 5	583-13113-00	C - 7	5NY-14459-00	B - 12	3TJ-14933-40	B - 15	5XC-15373-00	C - 4	2S2-18140-10	C - 12
3LD-12168-20	B - 5	2S2-13300-10	B - 10	5JG-14521-00	B - 13	5TA-14934-00	C - 2			5TJ-18172-00	C - 13
3LD-12168-40	B - 5	5TA-13320-00	B - 10	5JG-14522-00	B - 13	5JG-14940-16	B - 15	2S2-15378-00	C - 6	3XJ-18173-10	C - 13
3LD-12168-60	B - 5	2S2-13341-00	B - 10	5JG-14531-00	C - 2	5JG-14940-17	B - 15	4JT-15381-01	C - 4	3XJ-18178-00	C - 13
3LD-12168-80	B - 5	2S2-13342-00	B - 10	3TJ-14536-40	B - 15	5JG-14940-18	B - 15	5BE-15383-01	C - 4	3XJ-18182-00	C - 13
3LD-12168-A0	B - 5	5BE-13411-00	B - 10	5JG-14546-01	B - 13	5TA-14943-27	B - 15	2S2-15388-00	C - 4	3XJ-18184-00	C - 13
3LD-12168-F0	B - 5	2S2-13412-00	B - 10	676-14548-00	B - 15	4MX-14943-37	B - 14	2S2-15411-00	C - 6	2S2-18185-00	C - 13
3LD-12168-H1	B - 5	5TA-13440-00	B - 11	4MX-14561-00	C - 2	4MX-14943-38	B - 14	5TA-15415-10	C - 6	2S2-18501-00	C - 12
3LD-12168-K1	B - 5	5BE-13447-10	B - 11	6H4-14561-00	B - 15	2S2-14943-39	B - 14	2S2-15421-00	C - 4	2S2-18502-00	C - 12
3LD-12168-M1	B - 5	2S2-13597-00	B - 12	5NX-14562-00	C - 2	4MX-14943-40	B - 14	2S2-15431-00	C - 6	5BE-18503-00	C - 12
3LD-12168-R1	B - 5	2S2-14101-70	B - 13	3TJ-14564-40	C - 2	4MX-14943-41	B - 14	2S2-15441-00	B - 3	5NL-18541-00	C - 12

NUMERICAL INDEX

PART NO.	GRID NO.	PART NO.	GRID NO.	PART NO.	GRID NO.	PART NO.	GRID NO.	PART NO.	GRID NO.	PART NO.	GRID NO.
278-18542-00	C - 12	5XC-2173F-10	D - 4	5XE-22242-00	D - 8	509-23184-L0	D - 7	1C3-25181-10	E - 2	5DH-25916-00	E - 3
2S2-18562-00	C - 4	2S2-2173L-00	D - 4	1C3-22253-50	D - 7	1C3-23188-L0	D - 10	5NY-25183-00	E - 2		E - 6
2S2-21101-00	C - 14	2S2-21740-70	D - 4	1C3-22253-L0	D - 7	1C3-23188-N0	D - 10	5NY-25186-00	E - 2	3JD-25917-00	E - 3
2S2-21163-70	C - 15	5XC-21740-90	D - 4	4AA-22259-40	D - 7	1C3-23188-P0	D - 10	5HD-25304-00	E - 4		E - 6
5XC-21164-90	C - 15	2S2-2174L-00	D - 4	4AA-22259-50	D - 7	1C3-23188-R0	D - 10	5TJ-2530S-80	E - 5	5DH-25919-00	E - 3
5PA-2118K-00	D - 2	2S2-22110-70	D - 5	4AA-22259-60	D - 7	1C3-23190-L0	D - 10	5ET-25311-00	E - 4	5DH-25919-50	E - 6
5PA-2118K-10	D - 2	5XC-22121-91	D - 6	4AA-22259-80	D - 7	2S2-23340-L0	D - 11	5ET-25317-00	E - 4	8CR-25924-00	E - 6
5PA-2118K-20	D - 2	1C3-22122-00	D - 6	1P8-22355-00	D - 5	3SP-23356-L0	D - 12	4XM-25364-00	E - 4	3SP-25926-51	E - 3
2S2-21190-70	C - 14	2S2-22128-70	D - 5	4EW-22474-00	D - 7	5XE-23389-00	D - 9	1C3-25381-90	E - 5	5DH-25933-00	E - 3
1C3-21244-10	C - 15	1C3-22141-10	D - 5	3JE-22475-00	D - 7	4EW-23416-00	D - 9	1C3-25388-50	E - 5	1UY-25937-51	E - 3
5XC-21274-90	C - 15	2S2-22151-70	D - 5	5NY-22475-00	D - 7	2S2-23435-70	D - 9	1C3-25389-00	E - 5		E - 6
5XC-21288-90	C - 15	5UN-22176-00	D - 7	1C3-22565-00	D - 7	5XC-23441-90	D - 9	3JE-25394-00	E - 4	1C3-26111-90	E - 7
1C3-2135F-00	D - 6	30X-22178-00	C - 14	5UN-22898-60	E - 6	2S2-23442-70	D - 9	5SF-25394-00	E - 2	5XC-26124-90	E - 7
1C3-2139R-00	D - 6	3JD-22178-20	C - 14	1C3-22969-90	D - 5	1C3-23466-50	D - 12	1C3-25447-00	E - 4	2S2-26143-70	E - 7
2S2-21417-00	C - 15	5XC-2217A-90	D - 5	2S2-23102-50	D - 10	1C3-23467-50	D - 12	1C3-25448-00	E - 4	5XC-26143-90	E - 7
2S2-21425-70	C - 14	5XC-2217F-90	D - 5	2S2-23102-60	D - 10	1C3-23485-70	D - 9	1C3-25449-00	E - 4	5TJ-26240-C0	E - 7
2S2-21426-70	C - 14	4V4-22184-00	C - 14	2S2-23103-50	D - 10	2S2-24110-70	D - 13	1C3-25450-00	E - 4	4GY-26241-00	E - 7
1C3-21447-10	C - 14	5MV-22184-00	D - 7	2S2-23103-60	D - 10	4EW-2412F-00	D - 13	1C3-25451-00	E - 4	4GY-26242-00	E - 7
1C3-21448-10	C - 14	2S2-22199-70	D - 5	1C3-23110-M0	D - 11	5XE-24144-00	D - 13	1C3-25452-00	E - 4	3Y1-26249-00	E - 7
5XC-21456-90	C - 15	2S2-22200-50	D - 7	1C3-23111-L1	D - 10	3FB-2415E-01	D - 2	5CG-25715-00	E - 8	5BE-26281-00	E - 7
2S2-21471-00	C - 15	2S2-22200-60	D - 7	276-23114-00	D - 10	3ME-2415E-01	D - 3		E - 10	5BE-26282-00	E - 7
2S2-2147E-00	C - 15	2S2-22200-70	D - 7	1C3-23120-M0	D - 10	3FB-2415E-11	D - 2	1C3-25718-50	E - 6	5SF-26287-10	E - 7
1C3-21511-51	D - 2	2S2-22200-80	D - 7	5XE-23125-L0	D - 10	3FB-2415E-C0	D - 2	1C3-2580T-00	E - 3	2S2-26302-00	E - 7
2S2-21511-70	D - 2	2S2-22200-90	D - 7	1C3-23136-M0	D - 10	4SR-2416E-00	D - 2	1C3-2580W-50	E - 6	2S2-26334-00	E - 12
4LB-2151H-02	D - 2	2S2-22201-50	D - 7	1C3-23141-A1	E - 14	5XC-24181-90	D - 13	2S2-2581T-70	E - 3	2S2-26335-70	E - 7
3XJ-2151H-A1	D - 2	2S2-22201-60	D - 7	1C3-23141-B1	E - 14	5XC-24182-90	D - 14	5UN-25827-60	E - 6	5HD-26337-00	E - 12
3XJ-2151H-B1	D - 3	1C3-22212-00	E - 14	1C3-23141-C1	E - 14	5XC-24183-90	D - 14	5UN-25828-60	E - 6	5TA-26339-00	E - 12
4XL-2153A-10	D - 12	5UN-22212-00	E - 14	1C3-23141-D1	E - 14	3JD-24186-00	D - 13	2S2-2582W-70	E - 6	1C3-26342-50	E - 7
5XC-2153E-00	D - 2	1C3-22212-10	E - 14	1C3-23141-E1	E - 14	5XC-2419A-90	D - 13	5MV-25833-00	E - 8	5HD-26372-00	E - 12
4ES-2153E-01	D - 2	1C3-22212-20	E - 14	1C3-23141-F1	E - 14	2S2-24311-00	D - 13	1C3-2583V-00	E - 10	5NY-26372-00	E - 8
5XC-2153E-10	D - 2	1C3-22212-30	E - 14	1C3-23141-G1	E - 14	5XC-24339-90	D - 13	5DH-25849-00	E - 3	2S2-27200-10	E - 9
4ES-2153E-20	D - 2	1C3-22212-40	E - 14	1C3-23141-J1	E - 14	3XJ-24380-00	D - 13	5MV-25852-01	E - 8	5UN-27217-00	E - 10
5PA-21568-00	D - 3	1C3-22212-50	D - 7	2S2-23141-L1	D - 10	4JT-24500-10	D - 13	5UN-25852-50	E - 10	1C3-27217-10	E - 9
2S2-21610-70	D - 2		E - 14	1C3-23142-L0	D - 10	4X8-24512-00	D - 13	5XE-25853-00	E - 8	5UN-27218-00	E - 10
5XC-21610-90	D - 2	1C3-22212-60	E - 14	5XE-23144-L0	D - 10	3AC-24523-00	D - 13	5UN-25854-00	E - 10	5UN-27222-00	E - 10
5XE-21635-10	D - 2	5UN-22212-A0	E - 14	1C3-23145-M0	D - 10	3AJ-24534-01	D - 13	5XE-25854-00	E - 8	1C3-27311-00	E - 9
2S2-2163G-00	D - 3	5UN-22212-B0	E - 14	5XE-23146-L0	D - 10	5NY-24610-00	D - 13	5UN-2585B-00	E - 10	5XE-27411-01	E - 9
5TA-21642-00	D - 2	5UN-22212-C0	E - 14	1AE-23147-00	D - 10	2S2-2470F-80	D - 15	5MV-25867-00	E - 8	5XE-27421-01	E - 9
2S2-2165A-00	D - 3	5UN-22212-D0	E - 14	1C3-23147-L0	D - 10	5XC-2470F-90	D - 15	5NY-25868-00	E - 8	1C3-27491-50	E - 6
3RV-21668-A0	D - 6	5UN-22212-E0	E - 14	1C3-2314F-M0	D - 10	5XC-2470F-A0	D - 15	1C3-25872-90	E - 8	5XC-28116-00	C - 15
3RV-21668-B0	D - 6	5UN-22212-F0	E - 14	5XE-23153-L0	D - 10	5XC-2470F-B0	D - 15	1C3-25873-00	E - 10	5TA-2814F-00	C - 15
5XC-21710-90	D - 4	5UN-22212-G0	E - 14	2HH-23158-L0	D - 10	2S2-24710-70	D - 15	1C3-25875-50	E - 3	5ET-28166-10	C - 15
5XC-21720-90	D - 4	1C3-22213-L0	D - 7	1C3-2315H-10	D - 12	2S2-24710-80	D - 15	1C3-25876-50	E - 10	5TA-82310-10	E - 13
2S2-2172A-70	D - 4	1C3-22214-50	D - 7	1C3-2315J-10	D - 12	5XC-24710-A0	D - 15	1C3-25886-50	E - 10	2S2-82509-00	E - 13
2S2-2172A-80	D - 4	5MV-22224-00	D - 7	1C3-2316A-R0	D - 10	5XC-24710-B0	D - 15	5MV-2589F-00	E - 8	2S2-82540-00	E - 13
2S2-21730-70	D - 4	4JX-22226-00	D - 7	1C3-23170-R0	D - 10	5NY-25104-00	E - 2	5UN-25914-00	E - 6	5XE-82911-00	E - 12
5XC-21730-90	D - 4	3SP-22234-00	D - 7	5XE-23171-L0	D - 10	5NY-25111-00	E - 2	5DH-25914-50	E - 6	5XD-82913-00	E - 12
5XC-2173E-10	D - 4	5NY-22241-00	D - 8	5DH-23183-00	D - 7	5NY-25117-00	E - 2	3SP-25914-51	E - 3	5XD-82946-00	E - 12

NUMERICAL INDEX

PART NO.	GRID NO.	PART NO.	GRID NO.	PART NO.	GRID NO.	PART NO.	GRID NO.	PART NO.	GRID NO.	PART NO.	GRID NO.
5MV-83912-00	E - 12	90105-08143	C - 15	90179-10658	C - 14	90206-06090	C - 3	90430-10005	E - 8	91402-25015	E - 9
1C3-83922-50	E - 8	90105-08146	C - 14	90179-12657	E - 11	90208-25045	C - 9		E - 10	91808-16023	B - 2
5TA-83941-00	E - 12	90105-08154	D - 9	90179-16011	E - 2	90209-06014	B - 12	90430-10188	C - 4	91812-16001	C - 6
5HD-83951-00	E - 12		D - 11	90179-20001	C - 11	90209-16011	D - 5	90445-09220	D - 13	91A20-05065	B - 9
1C3-83976-00	E - 12	90105-08156	C - 14	90179-20009	C - 9	90209-21332	C - 10	90445-09251	D - 13	92012-05008	C - 15
5LP-84126-10	E - 12	90105-08307	C - 3	90179-28003	D - 9	90209-26348	C - 10	90445-14009	B - 10	92012-05012	E - 12
2S2-85540-70	E - 13		C - 14	90183-060A6	B - 9	90215-10009	B - 4	90450-17001	B - 10	92012-06010	B - 9
2S2-85540-80	E - 13	90105-10163	B - 2	90185-08008	E - 5	90215-14287	B - 4	90450-22001	B - 9	92902-06600	B - 7
1C3-85546-00	E - 13	90105-10176	C - 14	90185-08009	C - 14	90215-20005	C - 9	90450-25001	B - 9	92902-08200	C - 15
2S2-85550-00	E - 11	90105-10189	C - 14	90185-10012	D - 8	90215-21003	C - 11	90450-28001	B - 9	92902-10200	D - 8
2S2-85560-00	E - 11	90105-10191	C - 14	90185-14010	D - 6	90240-08120	E - 9	90450-57010	B - 12		D - 9
5XC-85885-00	C - 2	90105-10193	C - 14	90185-16002	D - 5	90240-10004	E - 9	90450-61002	B - 12	93101-14164	C - 6
5NY-W0041-00	E - 8	90109-06034	E - 12	90185-20002	E - 5	90267-32070	B - 12	90461-10136	C - 5	93102-12106	B - 8
5UN-W0042-50	E - 10	90109-06198	C - 12	90201-03313	B - 12	90267-48084	C - 3	90464-13073	E - 13	93102-12224	C - 9
5MV-W0045-01	E - 3	90109-06203	B - 2	90201-06013	C - 12		E - 15	90464-13077	E - 13		C - 13
1C3-W0046-50	E - 6	90109-067F4	B - 12	90201-06032	D - 2	90280-03006	B - 4	90464-15195	E - 13	93102-20108	C - 8
3JD-W0047-00	E - 3	90109-08078	E - 5	90201-06570	D - 13	90282-05034	B - 4	90465-13275	D - 14	93102-26468	E - 2
5UN-W0047-50	E - 6	90110-05038	B - 12	90201-06571	B - 9	90340-12007	B - 2		E - 13	93102-32480	C - 11
1UY-W0048-50	E - 3	90110-06228	B - 11		D - 2	90340-14128	C - 6	90467-090A2	B - 9	93106-22002	D - 5
	E - 6	90110-08087	C - 8	90201-08043	C - 14	90340-27002	C - 6	90467-100A1	D - 14	93106-30001	E - 4
5UN-W0057-00	E - 3	90110-08097	C - 3	90201-08044	E - 9	90387-06009	D - 2	90467-140A4	B - 2	93106-30045	E - 4
5UN-W0057-50	E - 6	90111-06059	E - 10	90201-08045	C - 14	90387-06065	B - 9	90468-16001	E - 9	93109-11073	B - 8
5XE-W2587-10	E - 8	90116-08022	B - 2	90201-08047	C - 8		D - 13	90480-08608	E - 5	93109-22019	D - 6
90101-06041	C - 13	90119-06146	C - 15	90201-08048	E - 5	90387-06090	D - 2	90480-15528	B - 9	93109-25001	D - 5
90101-06044	C - 8		D - 9	90201-08061	C - 3		D - 13	90480-18549	D - 13	93109-28043	D - 5
90101-08006	E - 5	90119-06147	D - 2	90201-08410	C - 2	90387-06104	D - 9	90501-043E0	C - 7	93210-07135	B - 11
90105-05014	C - 15	90119-08095	D - 4	90201-08512	B - 8	90387-08041	C - 14	90501-052G5	C - 13	93210-08003	C - 6
90105-06027	B - 2	90122-06005	B - 12	90201-10025	B - 2	90387-08081	C - 3	90501-06022	C - 12	93210-09165	C - 5
90105-06064	D - 4	90149-05162	E - 12	90201-10032	E - 9		E - 15	90501-147A5	C - 8	93210-10197	C - 4
90105-06081	C - 4	90149-06068	B - 10	90201-10045	C - 14	90387-086N4	C - 14	90501-160A2	C - 8	93210-11073	E - 9
	C - 11	90149-06074	C - 4	90201-12166	B - 10	90387-124F4	C - 13	90501-230E4	C - 9	93210-14369	C - 6
90105-06100	D - 2	90149-06081	E - 11	90201-125L6	C - 9	90387-14009	D - 6	90506-16007	E - 9	93210-16500	B - 9
90105-06103	D - 4	90149-06083	B - 4	90201-127E1	C - 13	90387-16010	D - 5	90508-26021	C - 12	93210-17570	C - 8
90105-06104	D - 5	90149-06108	D - 14		E - 11	90387-18004	D - 5	90508-28015	E - 9	93210-19123	C - 6
90105-06105	D - 5	90149-06327	E - 3	90201-14020	D - 6	90387-18007	C - 4	90508-28018	E - 9	93210-19758	B - 8
	E - 3	90149-10031	C - 14	90201-15701	C - 6	90387-18012	D - 5	90508-29021	C - 13	93210-21276	E - 13
90105-06106	D - 2	90151-04003	D - 5	90201-16018	D - 5	90387-20028	C - 10	90508-305B0	C - 8	93210-22164	C - 11
90105-06107	D - 9	90151-06032	C - 15	90201-162H4	C - 8	90387-21005	C - 10	91312-06012	B - 9	93210-27370	C - 6
	D - 13	90151-06044	C - 4	90201-167P7	C - 8	90387-225N2	E - 7	91312-06020	B - 11	93210-47675	B - 11
	E - 6	90152-06010	C - 8	90201-20020	E - 5	90387-2513F	C - 11		B - 12	93300-60839	C - 14
90105-06108	E - 6	90154-05022	E - 13	90201-203E7	C - 10	90387-28012	C - 10	91312-06030	B - 10	93304-20310	B - 4
90105-06110	E - 6	90159-06010	C - 9	90201-20685	C - 8	90401-10172	E - 8		C - 4	93306-00105	B - 8
90105-06111	B - 9	90170-10405	B - 4	90201-21014	D - 5		E - 10	91312-06050	C - 4	93306-00426	C - 10
	D - 13	90170-14171	B - 4	90201-24016	D - 9	90430-06014	B - 2	91312-06060	C - 4	93306-00431	C - 10
	E - 6	90170-20327	C - 9	90201-253K0	C - 10		B - 7	91312-06065	B - 11	93306-07202	E - 4
90105-08134	D - 11	90170-24003	D - 9	90201-286K9	D - 9		B - 8	91312-06080	C - 4	93306-20532	C - 10
90105-08137	C - 3	90179-06028	D - 5	90202-05193	D - 14		C - 5	91316-04012	B - 13	93306-205A5	C - 10
	E - 3	90179-08674	E - 5	90202-08045	B - 13	90430-08119	C - 4	91402-20012	E - 9	93306-27212	E - 4

NUMERICAL INDEX

PART NO.	GRID NO.	PART NO.	GRID NO.	PART NO.	GRID NO.	PART NO.	GRID NO.	PART NO.	GRID NO.	PART NO.	GRID NO.
93306-30633	B - 4	94703-00410	B - 2								
93306-80501	C - 12	94703-00411	B - 2								
93306-90409	E - 2	95022-06010	B - 2								
93306-90509	C - 12	95022-06012	B - 9								
93310-63417	B - 4		C - 5								
93315-32166	D - 5	95022-06016	B - 3								
93315-32269	D - 5	95022-06020	C - 13								
93317-11287	C - 9	95022-06025	B - 7								
93317-22262	D - 5	95022-06030	B - 8								
93332-00068	D - 9		B - 10								
93332-00081	D - 11		C - 6								
93340-21505	C - 9	95022-06035	B - 2								
93342-22217	D - 5	95022-06040	C - 6								
93410-20038	C - 8	95022-06080	C - 7								
93420-18082	B - 4	95022-08040	C - 14								
93440-10085	C - 9	95022-10016	C - 4								
93440-10153	B - 10	95602-05100	E - 12								
93440-25084	C - 10	95602-10200	D - 8								
93440-28062	C - 10		D - 9								
93440-41178	B - 7	95701-06500	E - 8								
93503-08007	C - 7	95702-06500	D - 12								
93507-32009	C - 8	95702-08500	B - 2								
93511-32027	C - 9	95822-08016	C - 4								
93603-16219	B - 10	97002-05016	E - 12								
93604-10011	B - 8	97022-06016	B - 7								
93608-33002	C - 13	97702-60016	D - 2								
93612-16254	B - 3	98502-03008	D - 13								
9383E-13233	C - 11	98502-05010	E - 10								
94108-21012	E - 2	98502-05020	E - 7								
94108-21015	E - 2	98502-06025	C - 4								
94108-2112Y	E - 2	98702-06025	D - 13								
94111-19011	E - 4	98706-04012	E - 8								
94111-19015	E - 4	98980-06008	C - 3								
94111-1913A	E - 4	99009-12400	B - 10								
94209-21229	E - 2	99009-16400	C - 8								
94211-19273	E - 4	99009-20400	C - 8								
94211-19274	E - 4	99009-20500	C - 9								
94227-21101	E - 2	99009-22500	C - 6								
94309-21161	E - 2	99009-45500	E - 4								
94311-19155	E - 4	99530-08012	B - 10								
94321-19157	E - 4	99530-08016	C - 6								
94330-21084	E - 2	99530-10114	B - 10								
94416-21034	E - 2		C - 4								
94421-19005	E - 4	99530-14016	C - 4								
94591-57118	B - 7	9Y581-92113	E - 5								
94681-68001	E - 5										
94701-00410	B - 2										
94701-00411	B - 2										